

ThinkPad

Hardware Maintenance Manual

ThinkPad X230 and X230i

Note: Before using this information and the product it supports, be sure to read the general information under Appendix A “Notices” on page 95.

Second Edition (October 2012)

© Copyright Lenovo 2012.

LIMITED AND RESTRICTED RIGHTS NOTICE: If data or software is delivered pursuant a General Services Administration “GSA” contract, use, reproduction, or disclosure is subject to restrictions set forth in Contract No. GS-35F-05925.

Contents

About this manual	iii	How to remove the hard-disk password	32
Chapter 1. Safety information	1	Power management	33
General safety	1	Screen blank mode (for the Windows 7 operating system only)	33
Electrical safety	1	Sleep mode	33
Safety inspection guide	3	Hibernation mode	33
Handling devices that are sensitive to electrostatic discharge	3	Symptom-to-FRU index	34
Grounding requirements	4	Numeric error codes	35
Safety notices (multilingual translations)	4	Error messages	36
Chapter 2. Important service information	19	Beep symptoms	36
Strategy for replacing FRUs	19	No-beep symptoms	37
Strategy for replacing a hard disk drive	20	LCD-related symptoms	37
Important notice for replacing a system board	20	Intermittent problems	37
How to use error message	20	Undetermined problems	38
Strategy for replacing FRUs for CTO, CMV, and GAV	20	Chapter 5. Status indicators	39
Product definition	20	Chapter 6. Fn key combinations	41
FRU identification for CTO, CMV, and GAV products	21	Chapter 7. Locations	43
Chapter 3. General checkout	23	Locating computer controls, connectors, and indicators	43
What to do first	23	Front view	43
Checkout guide	24	Rear view	44
Lenovo Solution Center	24	Bottom view	44
Quick test programs	24	Locating FRUs and CRUs	44
UEFI diagnostic program	25	Major FRUs and CRUs	46
Bootable diagnostic programs	25	LCD FRUs and CRUs	48
Power system checkout	26	Looking up FRU information	49
Checking the ac power adapter	26	Chapter 8. FRU replacement notices	51
Checking operational charging	27	Screw notices	51
Checking the battery pack	27	Retaining serial numbers	52
Checking the backup battery	28	Restoring the serial number of the system unit	52
Chapter 4. Related service information	29	Retaining the UUID	53
Restoring the factory contents by using Recovery Disc Set	29	Reading or writing the ECA information	53
Using the Windows recovery programs on the Windows 8 operating system	30	Chapter 9. Removing or replacing a FRU	55
Passwords	31	General guidelines	55
Power-on password	31	Before servicing the computer	56
Hard-disk password	31	Removing the SIM card	56
Supervisor password	32	1010 Battery pack	56
How to remove the power-on password	32	1020 Hard disk drive or solid-state drive	57
		1030 Memory module	59
		1040 Keyboard	60

1050 Palm rest	63
1060 Backup battery	65
1070 Speaker assembly	66
1080 PCI Express Mini Card for wireless LAN/WiMAX.	68
1090 PCI Express Mini Card for wireless WAN or mSATA solid-state drive	70
1100 Bluetooth daughter card	74
1110 Keyboard bezel	75
1120 LCD unit	77
1130 Base cover assembly	80
1140 Systemboard, DC-in connector, thermal fan assembly, and ExpressCard slot.	82

2010 LCD front bezel	85
2020 Integrated camera	86
2030 LCD panel	87
2040 LED board	88
2050 Hinges	89
2060 LCD cable	90
2070 LCD rear cover assembly, LED and camera cable, and wireless antenna set	91

Appendix A. Notices.	95
Electronic emission notices.	96
Trademarks	96

About this manual

This manual contains service and reference information for the following ThinkPad® products.

ThinkPad X230 and X230i Machine Type 2306, 2320, 2322, 2324, 2325, 2330, and 2333

Use this manual along with the advanced diagnostic tests to troubleshoot problems.

Important:

This manual is intended only for trained service technicians who are familiar with ThinkPad products. Use this manual along with the advanced diagnostic tests to troubleshoot problems effectively.

Before servicing a ThinkPad product, be sure to read all the information under Chapter 1 “Safety information” on page 1 and Chapter 2 “Important service information” on page 19.

Chapter 1. Safety information

This chapter presents the following safety information that you need to be familiar with before you service a ThinkPad notebook computer.

- “General safety” on page 1
- “Electrical safety” on page 1
- “Safety inspection guide” on page 3
- “Handling devices that are sensitive to electrostatic discharge” on page 3
- “Grounding requirements” on page 4
- “Safety notices (multilingual translations)” on page 4

General safety

Follow these rules to ensure general safety:

- Observe good housekeeping in the area of the machines during and after maintenance.
- When lifting any heavy object:
 1. Ensure that you can stand safely without slipping.
 2. Distribute the weight of the object equally between your feet.
 3. Use a slow lifting force. Never move suddenly or twist when you attempt to lift.
 4. Lift by standing or by pushing up with your leg muscles; this action removes the strain from the muscles in your back. *Do not attempt to lift any object that weighs more than 16 kg (35 lb) or that you think is too heavy for you.*
- Do not perform any action that causes hazards to the customer, or that makes the equipment unsafe.
- Before you start the machine, ensure that other service technicians and the customer's personnel are not in a hazardous position.
- Place removed covers and other parts in a safe place, away from all personnel, while you are servicing the machine.
- Keep your toolcase away from walk areas so that other people will not trip over it.
- Do not wear loose clothing that can be trapped in the moving parts of a machine. Ensure that your sleeves are fastened or rolled up above your elbows. If your hair is long, fasten it.
- Insert the ends of your necktie or scarf inside clothing or fasten it with a nonconductive clip, about 8 centimeters (3 inches) from the end.
- Do not wear jewelry, chains, metal-frame eyeglasses, or metal fasteners for your clothing, because metal objects are good electrical conductors.
- Wear safety glasses when you are hammering, drilling, soldering, cutting wire, attaching springs, using solvents, or working in any other conditions that might be hazardous to your eyes.
- After service, reinstall all safety shields, guards, labels, and ground wires. Replace any safety device that is worn or defective.
- Reinstall all covers correctly before returning the machine to the customer.
- Fan louvers on the machine help to prevent overheating of internal components. Do not obstruct fan louvers or cover them with labels or stickers.

Electrical safety

Observe the following rules when working on electrical equipment.

Important:

- Use only approved tools and test equipment. Some hand tools have handles covered with a soft material that does not insulate you when working with live electrical currents.
- Many customers have, near their equipment, rubber floor mats that contain small conductive fibers to decrease electrostatic discharges. Do not use this type of mat to protect yourself from electrical shock.
- Find the room emergency power-off (EPO) switch, disconnecting switch, or electrical outlet. If an electrical accident occurs, you can then operate the switch or unplug the power cord quickly.
- Do not work alone under hazardous conditions or near equipment that has hazardous voltages.
- Disconnect all power before:
 - Performing a mechanical inspection
 - Working near power supplies
 - Removing or installing main units
- Before you start to work on the machine, unplug the power cord. If you cannot unplug it, ask the customer to power off the wall box that supplies power to the machine, and to lock the wall box in the off position.
- If you need to work on a machine that has exposed electrical circuits, observe the following precautions:
 - Ensure that another person, familiar with the power-off controls, is near you. That person must be there to switch off the power, if necessary.
 - Use only one hand when working with powered-on electrical equipment; keep the other hand in your pocket or behind your back.

CAUTION:

An electrical shock can occur only when there is a complete circuit. By observing the above rule, you may prevent a current from passing through your body.

- When using testers, set the controls correctly and use the approved probe leads and accessories for that tester.
- Stand on suitable rubber mats (obtained locally, if necessary) to insulate you from grounds such as metal floor strips and machine frames.

Observe the special safety precautions when you work with very high voltages. Instructions for these precautions are in the safety sections of maintenance information. Use extreme care when measuring high voltages.

- Regularly inspect and maintain your electrical hand tools for safe operational condition.
- Do not use worn or broken tools and testers.
- Never assume that power has been disconnected from a circuit. First, check that it has been powered off.
- Always look carefully for possible hazards in your work area. Examples of these hazards are moist floors, nongrounded power extension cables, power surges, and missing safety grounds.
- Do not touch live electrical circuits with the reflective surface of a plastic dental mirror. The surface is conductive; such touching can cause personal injury and machine damage.
- Do not service the following parts with the power on:
 - Power supply units
 - Pumps
 - Blowers and fans
 - Motor generators
 - Units similar to those listed above

This practice ensures correct grounding of the units.

- If an electrical accident occurs:
 - Use caution; do not become a victim yourself.
 - Switch off power.
 - Send another person to get medical aid.

Safety inspection guide

The purpose of this inspection guide is to assist you in identifying potentially unsafe conditions. As each machine was designed and built, required safety items were installed to protect users and service technicians from injury. This guide addresses only those items. You should use good judgment to identify potential safety hazards due to attachment of non-ThinkPad features or options not covered by this inspection guide.

If any unsafe conditions are present, you must determine how serious the apparent hazard could be and whether you can continue without first correcting the problem.

Consider these conditions and the safety hazards they present:

- Electrical hazards, especially primary power (primary voltage on the frame can cause serious or fatal electrical shock)
- Explosive hazards, such as a damaged CRT face or a bulging capacitor
- Mechanical hazards, such as loose or missing hardware

To determine whether there are any potentially unsafe conditions, use the following checklist at the beginning of every service task. Begin the checks with the power off, and the power cord disconnected.

Checklist:

1. Check exterior covers for damage (loose, broken, or sharp edges).
2. Power off the computer. Disconnect the power cord.
3. Check the power cord for:
 - a. A third-wire ground connector in good condition. Use a meter to measure third-wire ground continuity for 0.1 ohm or less between the external ground pin and the frame ground.
 - b. The power cord should be the authorized type specified for your computer. Go to <http://www.lenovo.com/serviceparts-lookup>.
 - c. Insulation must not be frayed or worn.
4. Check for cracked or bulging batteries.
5. Remove the cover.
6. Check for any obvious non-ThinkPad alterations. Use good judgment as to the safety of any non-ThinkPad alterations.
7. Check inside the unit for any obvious unsafe conditions, such as metal filings, contamination, water or other liquids, or signs of fire or smoke damage.
8. Check for worn, frayed, or pinched cables.
9. Check that the power-supply cover fasteners (screws or rivets) have not been removed or tampered with.

Handling devices that are sensitive to electrostatic discharge

Any computer part containing transistors or integrated circuits (ICs) should be considered sensitive to electrostatic discharge (ESD). ESD damage can occur when there is a difference in charge between objects. Protect against ESD damage by equalizing the charge so that the machine, the part, the work mat, and the person handling the part are all at the same charge.

Notes:

1. Use product-specific ESD procedures when they exceed the requirements noted here.
2. Ensure that the ESD protective devices you use have been certified (ISO 9000) as fully effective.

When handling ESD-sensitive parts:

- Keep the parts in protective packages until they are inserted into the product.
- Avoid contact with other people.
- Wear a grounded wrist strap against your skin to eliminate static on your body.
- Prevent the part from touching your clothing. Most clothing is insulative and retains a charge even when you are wearing a wrist strap.
- Use a grounded work mat to provide a static-free work surface. The mat is especially useful when handling ESD-sensitive devices.
- Select a grounding system, such as those listed below, to provide protection that meets the specific service requirement.

Note: The use of a grounding system to guard against ESD damage is desirable but not necessary.

- Attach the ESD ground clip to any frame ground, ground braid, or green-wire ground.
- When working on a double-insulated or battery-operated system, use an ESD common ground or reference point. You can use coax or connector-outside shells on these systems.
- Use the round ground prong of the ac plug on ac-operated computers.

Grounding requirements

Electrical grounding of the computer is required for operator safety and correct system function. Proper grounding of the electrical outlet can be verified by a certified electrician.

Safety notices (multilingual translations)

The safety notices in this section are provided in the following languages:

- English
- Arabic
- Brazilian Portuguese
- French
- German
- Hebrew
- Japanese
- Korean
- Spanish
- Traditional Chinese



DANGER

Before the computer is powered on after FRU replacement, make sure that all screws, springs, and other small parts are in place and are not left loose inside the computer. Verify this by shaking the computer and listening for rattling sounds. Metallic parts or metal flakes can cause electrical short circuits.



DANGER

Some standby batteries contain a small amount of nickel and cadmium. Do not disassemble a standby battery, recharge it, throw it into fire or water, or short-circuit it. Dispose of the battery as required by local ordinances or regulations. Use only the battery in the appropriate parts listing. Use of an incorrect battery can result in ignition or explosion of the battery.



DANGER

The battery pack contains small amounts of nickel. Do not disassemble it, throw it into fire or water, or short-circuit it. Dispose of the battery pack as required by local ordinances or regulations. Use only the battery in the appropriate parts listing when replacing the battery pack. Use of an incorrect battery can result in ignition or explosion of the battery.



DANGER

The lithium battery can cause a fire, an explosion, or a severe burn. Do not recharge it, remove its polarized connector, disassemble it, heat it above 100°C (212°F), incinerate it, or expose its cell contents to water. Dispose of the battery as required by local ordinances or regulations. Use only the battery in the appropriate parts listing. Use of an incorrect battery can result in ignition or explosion of the battery.



DANGER

If the LCD breaks and the fluid from inside the LCD gets into your eyes or on your hands, immediately wash the affected areas with water for at least 15 minutes. Seek medical care if any symptoms from the fluid are present after washing.



DANGER

To avoid shock, do not remove the plastic cover that protects the lower part of the inverter card.



DANGER

Though the main batteries have low voltage, a short-circuited or grounded battery can produce enough current to burn personnel or combustible materials.



DANGER

Unless hot swap is allowed for the FRU being replaced, do as follows before removing it: power off the computer, unplug all power cords from electrical outlets, remove the battery pack, and disconnect any interconnecting cables.



قبل إعادة تشغيل الحاسب بعد الانتهاء من استبدال FRU، تأكد من أنه قد تم إعادة كل من المسامير و السوست وكل الأجزاء الصغيرة الأخرى في أماكنهم ولم يتم فقدم داخل الحاسب. ويمكن التحقق من ذلك عن طريق هز الحاسب والاستماع لأي صوت صاخب يصدر منه. قد تؤدي الأجزاء أو الرقائق المعدنية إلى حدوث دائرة قصر.



تحتوي بعض البطاريات الاحتياطية على كمية صغيرة من مادتي النيكل والكاديوم. لا تقم بفك أو إعادة شحن البطارية الاحتياطية ولا تقم أيضا بالقائها في النار أو الماء ولا تتسبب في أحداث دائرة قصر بها. قم بالتخلص من البطارية كما هو موضح في القوانين المحلية. استخدم نوع البطارية المحدد والذي يوصى باستخدامه. حيث أنه قد يؤدي استخدام نوع بطارية غير صحيح إلى اشتعالها أو انفجارها.



تحتوي حزمة البطارية على كمية صغيرة من مادة النيكل. لا تقم بفكها أو القاءها في النار أو الماء ولا تتسبب في أحداث دائرة قصر بها. تخلص من حزمة البطارية وفقا لما هو موضح في القوانين المحلية. قم، عند استبدال حزمة البطارية، باستخدام الأنواع المحددة فقط والتي يوصى باستخدامها. حيث أنه قد يؤدي استخدام نوع بطارية غير صحيح إلى اشتعالها أو انفجارها.



قد تتسبب بطارية الليثيوم في حدوث حريق أو انفجار أو حدوث حروق شديدة. لا تقم بإعادة شحن البطارية أو إزالة موصل الاستقطاب الخاص بها ولا تحاول أيضا فكها أو تسخينها لأكثر من ١٠٠ درجة مئوية (٢١٢١ فهرنهايت) أو حرقها أو تعريض محتويات الخاتمة الخاصة بها للماء. قم بالتخلص من البطارية وفقا لما هو موضح في القوانين المحلية. استخدم نوع البطارية المحدد والذي يوصى باستخدامه. حيث أنه قد يؤدي استخدام نوع بطارية غير صحيح إلى اشتعالها أو انفجارها.



إذا ما انكسرت شاشة LCD ولاس السائل الداخلي عينيك أو يديك، قم في الحال بغسلهما بالماء لمدة لا تقل عن ١٥ دقيقة. إذا ما وجدت أي أعراض بعد الغسل اطلب عندئذ المساعدة الطبية.



خطر

لتجنب التعرض لأي صدمات، لا تلم بازالة الغطاء البلاستيكي الذي يحمي الجزء الأسفل من بطاقة العاكس.



خطر

على الرغم من أن البطاريات الرئيسية يكون لها جهد منخفض، إلا أنه قد تقوم البطاريات التي حدث قصور بها أو التي تم توصيلها أرضيا باصدار تيار يكفي لحدوث حروق للأفراد أو تعرض المواد القابلة للاشتعال للحريق.



خطر

ما لم يتم السماح بالتبديل الفوري لأي FRU الجاري استبداله بدون ضرورة اغلاق النظام، قم بتنفيذ ما يلي قبل ازالته. قم بايقاف تشغيل الحاسب ونزع كل أسلاك الطاقة من المخارج الكهربائية وقم أيضا بازالة حزمة البطارية ثم قم بفصل أي كابلات متصلة.



PERIGO

Antes de ligar o computador após a substituição da FRU, certifique-se de que todos os parafusos, molas e outras peças pequenas estejam no lugar e não estejam soltos dentro do computador. Verifique isso sacudindo o computador e procurando ouvir sons de peças soltas. Peças metálicas ou lascas de metal podem causar curto-circuito.



PERIGO

Algumas baterias reserva contêm uma pequena quantidade de níquel e cádmio. Não desmonte uma bateria reserva, recarregue-a, jogue-a no fogo ou na água, ou deixe-a entrar em curto-circuito. Descarte a bateria conforme requerido pelas leis ou regulamentos locais. Use somente a bateria nas partes listadas apropriadas. O uso de uma bateria incorreta pode resultar em combustão ou explosão da bateria.



PERIGO

O pacote da bateria contém uma pequena quantidade de níquel. Não o desmonte, jogue-o no fogo ou na água, ou deixe-o entrar em curto-circuito. Descarte o pacote da bateria conforme requerido pelas leis ou regulamentos locais. Use somente a bateria nas partes listadas apropriadas ao substituir o pacote da bateria. O uso de uma bateria incorreta pode resultar em combustão ou explosão da bateria.



PERIGO

A bateria de lítio pode causar incêndio, explosão ou graves queimaduras. Não a recarregue, remova seu conector polarizado, desmonte-a, aqueça-a acima de 100°C (212°F), incinere-a, ou exponha o conteúdo de sua célula à água. Descarte a bateria conforme requerido pelas leis ou regulamentos locais. Use somente a bateria nas partes listadas apropriadas. O uso de uma bateria incorreta pode resultar em combustão ou explosão da bateria.



PERIGO

Se o LCD quebrar e o fluido de dentro dele entrar em contato com seus olhos ou com suas mãos, lave as áreas afetadas imediatamente com água durante pelo menos 15 minutos. Procure cuidados médicos se algum sintoma causado pelo fluido surgir após a lavagem.



PERIGO

Para evitar choque elétrico, não remova a capa plástica que protege a parte inferior da placa inversora.



PERIGO

Embora as principais baterias possuam baixa voltagem, uma bateria em curto-circuito ou aterrada pode produzir corrente o bastante para queimar materiais de pessoal ou inflamáveis.



PERIGO

A menos que uma hot swap seja permitida para a FRU que está sendo substituída, faça o seguinte antes de removê-la: desligue o computador, desconecte todos os cabos de energia das tomadas, remova o pacote de baterias e desconecte quaisquer cabos de interconexão.



DANGER

Avant de remettre l'ordinateur sous tension après remplacement d'une unité en clientèle, vérifiez que tous les ressorts, vis et autres pièces sont bien en place et bien fixées. Pour ce faire, secouez l'unité et assurez-vous qu'aucun bruit suspect ne se produit. Des pièces métalliques ou des copeaux de métal pourraient causer un court-circuit.



DANGER

Certaines batteries de secours contiennent du nickel et du cadmium. Ne les démontez pas, ne les rechargez pas, ne les exposez ni au feu ni à l'eau. Ne les mettez pas en court-circuit. Pour les mettre au rebut, conformez-vous à la réglementation en vigueur. Lorsque vous remplacez la pile de sauvegarde ou celle de l'horloge temps réel, veillez à n'utiliser que les modèles cités dans la liste de pièces détachées adéquate. Une batterie ou une pile inappropriée risque de prendre feu ou d'exploser.



DANGER

La batterie contient du nickel. Ne la démontez pas, ne l'exposez ni au feu ni à l'eau. Ne la mettez pas en court-circuit. Pour la mettre au rebut, conformez-vous à la réglementation en vigueur. Lorsque vous remplacez la batterie, veillez à n'utiliser que les modèles cités dans la liste de pièces détachées adéquate. En effet, une batterie inappropriée risque de prendre feu ou d'exploser.



DANGER

La pile de sauvegarde contient du lithium. Elle présente des risques d'incendie, d'explosion ou de brûlures graves. Ne la rechargez pas, ne retirez pas son connecteur polarisé et ne la démontez pas. Ne l'exposez pas à une température supérieure à 100°C, ne la faites pas brûler et n'en exposez pas le contenu à l'eau. Mettez la pile au rebut conformément à la réglementation en vigueur. Une pile inappropriée risque de prendre feu ou d'exploser.



DANGER

Si le panneau d'affichage à cristaux liquides se brise et que vous recevez dans les yeux ou sur les mains une partie du fluide, rincez-les abondamment pendant au moins quinze minutes. Consultez un médecin si des symptômes persistent après le lavage.



DANGER

Afin d'éviter tout risque de choc électrique, ne retirez pas le cache en plastique protégeant la partie inférieure de la carte d'alimentation.



DANGER

Bien que le voltage des batteries principales soit peu élevé, le court-circuit ou la mise à la masse d'une batterie peut produire suffisamment de courant pour brûler des matériaux combustibles ou causer des brûlures corporelles graves.



DANGER

Si le remplacement à chaud n'est pas autorisé pour l'unité remplaçable sur site que vous remplacez, procédez comme suit avant de retirer l'unité : mettez l'ordinateur hors tension, débranchez tous les cordons d'alimentation des prises de courant, retirez le bloc de batterie et déconnectez tous les câbles d'interconnexion.



VORSICHT

Bevor nach einem FRU-Austausch der Computer wieder angeschlossen wird, muß sichergestellt werden, daß keine Schrauben, Federn oder andere Kleinteile fehlen oder im Gehäuse vergessen wurden. Der Computer muß geschüttelt und auf Klappergeräusche geprüft werden. Metallteile oder-splitter können Kurzschlüsse erzeugen.



VORSICHT

Die Bereitschaftsbatterie, die sich unter dem Diskettenlaufwerk befindet, kann geringe Mengen Nickel und Cadmium enthalten. Sie darf nur durch die Verkaufsstelle oder den IBM Kundendienst ausgetauscht werden. Sie darf nicht zerlegt, wiederaufgeladen, kurzgeschlossen, oder Feuer oder Wasser ausgesetzt werden. Die Batterie kann schwere Verbrennungen oder Verätzungen verursachen. Bei der Entsorgung die örtlichen Bestimmungen für Sondermüll beachten. Beim Ersetzen der Bereitschafts- oder Systembatterie nur Batterien des Typs verwenden, der in der Ersatzteilliste aufgeführt ist. Der Einsatz falscher Batterien kann zu Entzündung oder Explosion führen.



VORSICHT

Akkus enthalten geringe Mengen von Nickel. Sie dürfen nicht zerlegt, wiederaufgeladen, kurzgeschlossen, oder Feuer oder Wasser ausgesetzt werden. Bei der Entsorgung die örtlichen Bestimmungen für Sondermüll beachten. Beim Ersetzen der Batterie nur Batterien des Typs verwenden, der in der Ersatzteilliste aufgeführt ist. Der Einsatz falscher Batterien kann zu Entzündung oder Explosion führen.



VORSICHT

Die Systembatterie ist eine Lithiumbatterie. Sie kann sich entzünden, explodieren oder schwere Verbrennungen hervorrufen. Batterien dieses Typs dürfen nicht aufgeladen, zerlegt, über 100°C erhitzt oder verbrannt werden. Auch darf ihr Inhalt nicht mit Wasser in Verbindung gebracht oder der zur richtigen Polung angebrachte Verbindungsstecker entfernt werden. Bei der Entsorgung die örtlichen Bestimmungen für Sondermüll beachten. Beim Ersetzen der Batterie nur Batterien des Typs verwenden, der in der Ersatzteilliste aufgeführt ist. Der Einsatz falscher Batterien kann zu Entzündung oder Explosion führen.



VORSICHT

Die Leuchtstoffröhre im LCD-Bildschirm enthält Quecksilber. Bei der Entsorgung die örtlichen Bestimmungen für Sondermüll beachten. Der LCD-Bildschirm besteht aus Glas und kann zerbrechen, wenn er unsachgemäß behandelt wird oder der Computer auf den Boden fällt. Wenn der Bildschirm beschädigt ist und die darin befindliche Flüssigkeit in Kontakt mit Haut und Augen gerät, sollten die betroffenen Stellen mindestens 15 Minuten mit Wasser abgespült und bei Beschwerden anschließend ein Arzt aufgesucht werden.



VORSICHT

Aus Sicherheitsgründen die Kunststoffabdeckung, die den unteren Teil der Spannungswandlerplatine umgibt, nicht entfernen.



VORSICHT

Obwohl Hauptbatterien eine niedrige Spannung haben, können sie doch bei Kurzschluß oder Erdung genug Strom abgeben, um brennbare Materialien zu entzünden oder Verletzungen bei Personen hervorzurufen.



VORSICHT

Wenn ein Austausch der FRU bei laufendem Betrieb nicht erlaubt ist, gehen Sie beim Austausch der FRU wie folgt vor: Schalten Sie den Computer aus, ziehen Sie alle Netzkabel von den Netzsteckdosen ab, entfernen Sie den Akku und ziehen Sie alle miteinander verbundenen Kabel ab.



לפני הפעלת המחשב לאחר החלפת FRU יש לוודא שכל חברגים, הקפיצים, וחלקים קטנים אחרים נמצאים במקומם ואינם חופשיים לזוז בתוך המחשב. כדי לוודא זאת, יש לטלטל את המחשב ולהקשיב לגילוי קולות שקשוק. חלקי או שבבי מתכת עלולים לגרום לקצרים חשמליים.



סוללות המתנה מסוימות מכילות כמוט קטנה של ניקל וקדמיום. אין למרק סוללות המתנה, לטעון אותה מחדש, להשליך אותה לאש או למים או לקצר אותה. יש לסלק את הסוללה כנדרש על ידי התקנות והחוקים המקומיים. יש להשתמש רק בסוללה המופיעה ברשימת החלקים המתאימה. שימוש בסוללה לא מתאימה עלול לגרום להצתה או התמוצות של הסוללה.



מארז הסוללה מכיל כמוט קטנה של ניקל וקדמיום. אין למרק את מארז הסוללה, להשליך אותו לאש או למים או לקצר אותו. יש לסלק את מארז הסוללה כנדרש על ידי התקנות והחוקים המקומיים. יש להשתמש רק בסוללה המופיעה ברשימת החלקים המתאימה בזמן החלפת מארז הסוללה. שימוש בסוללה לא מתאימה עלול לגרום להצתה או התמוצות של הסוללה.



סוללת הליתיום עלולה לגרום לשריפה, להתמוצות או לכוויות קשות. אין לטעון אותה מחדש, לסלק את המחבר המקוטב שלה, למרק אותה או לחמם אותה לסמפרטורה העולה על 100 מעלות צלזיוס. אין לשרוף את הסוללה ואין לחשוף את תוכן התא למים. יש לסלק את הסוללה כנדרש בתקנות ובחוקים המקומיים. יש להשתמש רק בסוללה המופיעה ברשימת החלקים המתאימים. שימוש בסוללה אחרת עלול לגרום לסכנת שריפה או התמוצות.



אם מסך הגביש נוזלי (LCD) נשבר והנוזל מתוך המסך בא במגע עם עיניכם או ידיכם, שטפו את האזורים הנוגעים מיד במים במשך 15 דקות לפחות. פנו לקבלת עזרה רפואית אם תסמינים הנובעים מהמגע עם הנוזל נמשכים לאחר הטיפול.



כדי למנוע התחשמלות, אין להסיר את מכסה הפלסטיק המגן על חלקו התחתון של הכרטיס החפץ.



אף שהסוללות הראשיות הן בעלות מתח נמוך, סוללה מקוצרת או מוארכת עלולה להפיק זרם מספיק לגרימת כוויות או להצתת חומרים דליקים.



אלא אם כן מותרת 'החלפה חמה' של ה-FRU המוחלף, פעלו כדלהלן לפני הסרתו:
כבו את המחשב, נתקו את כל כבלי החשמל מחשקעים, הוציאו את מארז הסוללות ונתקו את כל הכבלים
המחוברים.



危険

FRUの交換後、ThinkPadの電源を入れる前に、ねじ、パネ、その他の小さな部品がすべて正しい位置にあり、またThinkPadの内部で緩んでいないことを確認してください。
これを確認するには、ThinkPadを振って、カチャカチャと音がしないか確かめます。金属部品や金属破片はショートの原因になることがあります。



危険

予備バッテリーの中には少量のニッケルとカドミウムが含まれているものがあります。したがって、予備バッテリーの分解、再充電、火または水の中への投棄、またはショートさせることは決して行わないでください。バッテリーを廃棄する場合は地方自治体の条例に従ってください。適切なパーツ・リストにあるバッテリーだけを使用してください。誤ったバッテリーを使用すると、バッテリーが発火したり、爆発したりすることがあります。



危険

バッテリー・パックには少量のニッケルが含まれています。バッテリー・パックを分解したり、火または水の中に投げ込んだり、ショートさせないでください。バッテリー・パックの廃棄にあたっては、地方自治体の条例または規則に従ってください。バッテリー・パックを交換するときは、適切なパーツ・リストにあるバッテリーだけを使用してください。誤ったバッテリーを使用すると、バッテリーが発火したり、爆発したりすることがあります。



危険

リチウム・バッテリーは、火災、爆発、または重症のやけどを引き起こすことがあります。バックアップ・バッテリーの充電、その極性コネクターの取り外し、バッテリー本体の分解、100°C (212°F) 以上への加熱、焼却、電池の中身を水に浸すことはしないでください。バッテリーを廃棄する場合は地方自治体の条例に従ってください。適切なパーツ・リストにあるバッテリーだけを使用してください。誤ったバッテリーを使用すると、バッテリーが発火したり、爆発したりすることがあります。



危険

LCDが破損し、LCDの中の液体が目に入ったり、手に触れたりした場合は、液体が触れた部分を少なくとも15分間洗い流してください。洗い流した後に、液体によって何らかの症状が現れた場合は、医師の治療を受けてください。



危険

感電を防ぐため、インバーター・カードの下部を保護しているプラスチック・カバーを外さないでください。



危険

메인·배터리의電圧は低くても、ショートしたり、接地したバッテリーが、作業者にやけどを負わせたり、可燃物を燃やすだけの電流を発生させる場合があります。



危険

交換しようとしている FRU がホット・スワップに対応していない場合、それを取り外す前に、コンピューターの電源をオフにし、すべての電源コードをコンセントから抜き、バッテリー・パックを取り外して、相互接続しているケーブルをすべて切り離してください。



위험

FRU를 교체하고 나서 컴퓨터 전원을 켜기 전에 모든 나사, 스프링 및 기타 작은 부품들이 올바른 위치에 있는지, 컴퓨터 내부에 단단하게 연결되어 있는지 확인하십시오. 컴퓨터를 흔들어 달각거리는 소리가 나지 않는지 확인하십시오. 금속 부품 또는 금속 조각은 누전을 일으킬 수 있습니다.



위험

일부 보조 배터리에는 소량의 니켈 및 카드뮴이 포함되어 있습니다. 보조 배터리를 분해하거나, 다시 충전하거나, 불 또는 물에 던지거나, 단락시키지 마십시오. 배터리 팩을 폐기할 때에는 해당 지역의 법률 규정을 따르십시오. 배터리 팩을 교체할 때에는 올바른 배터리만 사용하십시오. 올바르지 않은 배터리를 사용하면 배터리가 발화되거나 폭발할 수 있습니다.



위험

배터리 팩에는 소량의 니켈이 포함되어 있습니다. 배터리 팩을 분해하거나, 불 또는 물에 던지거나, 단락시키지 마십시오. 배터리 팩을 폐기할 때에는 해당 지역의 법률 규정을 따르십시오. 배터리 팩을 교체할 때에는 올바른 배터리만 사용하십시오. 올바르지 않은 배터리를 사용하면 배터리가 발화되거나 폭발할 수 있습니다.



위험

리튬 배터리는 화재, 폭발 또는 심각한 화상을 일으킬 수 있습니다. 리튬 배터리를 다시 충전하거나, 극성 커넥터를 제거하거나, 분해하거나, 100C(212F) 이상으로 가열하거나, 소각하거나, 전지 내용물을 물에 노출시키지 마십시오. 배터리를 폐기할 때에는 해당 지역을 법률 규정을 따르십시오. 올바른 배터리만 사용하십시오. 올바르지 않은 배터리를 사용하면 배터리가 발화되거나 폭발할 수 있습니다.



위험

LCD가 파손되어 LCD 내부의 액체가 눈에 들어가거나 손에 묻으면 즉시 깨끗한 물로 15분 이상 닦아 내십시오. 씻은 후에 조금이라도 이상을 느끼면 즉시 병원에 가서 의사의 진찰을 받아야 합니다.



위험

전기적 위험을 방지하려면 인버터 카드의 아래 부분을 보호하는 플라스틱 덮개를 제거하지 마십시오.



기본 배터리의 전압은 낮지만, 단락되거나 접지된 배터리는 화상을 입히기에 충분한 전류와 가연성 물질을 발생시킬 수 있습니다.



FRU 교체 시 Hot Swap이 지원되지 않는 경우, FRU를 제거하기 전에 컴퓨터의 전원을 끄고, 전기 콘센트에서 전원 코드를 분리하고, 배터리를 제거한 후, 연결된 모든 케이블을 분리하십시오.



Antes de encender el sistema despues de sustituir una FRU, compruebe que todos los tornillos, muelles y demás piezas pequeñas se encuentran en su sitio y no se encuentran sueltas dentro del sistema. Compruébelo agitando el sistema y escuchando los posibles ruidos que provocarían. Las piezas metálicas pueden causar cortocircuitos eléctricos.



Algunas baterías de reserva contienen una pequeña cantidad de níquel y cadmio. No las desmonte, ni recargue, ni las eche al fuego o al agua ni las cortocircuite. Deséchelas tal como dispone la normativa local. Utilice sólo baterías que se encuentren en la lista de piezas. La utilización de una batería no apropiada puede provocar la ignición o explosión de la misma.



Las baterías contienen pequeñas cantidades de níquel. No las desmonte, ni recargue, ni las eche al fuego o al agua ni las cortocircuite. Deséchelas tal como dispone la normativa local. Utilice sólo baterías que se encuentren en la lista de piezas al sustituir la batería. La utilización de una batería no apropiada puede provocar la ignición o explosión de la misma.



La batería de repuesto es una batería de litio y puede provocar incendios, explosiones o quemaduras graves. No la recargue, ni quite el conector polarizado, ni la desmonte, ni caliente por encima de los 100°C (212°F), ni la incinere ni exponga el contenido de sus celdas al agua. Deséchela tal como dispone la normativa local.



Si la LCD se rompe y el fluido de su interior entra en contacto con sus ojos o sus manos, lave inmediatamente las áreas afectadas con agua durante 15 minutos como mínimo. Obtenga atención medica si se presenta algún síntoma del fluido despues de lavarse.



PELIGRO

Para evitar descargas, no quite la cubierta de plástico que rodea la parte baja de la tarjeta invertida.



PELIGRO

Aunque las baterías principales tienen un voltaje bajo, una batería cortocircuitada o con contacto a tierra puede producir la corriente suficiente como para quemar material combustible o provocar quemaduras en el personal.



PELIGRO

Salvo que se permita el intercambio en caliente para la unidad sustituable localmente, realice lo siguiente antes de extraerla: apague el sistema, desconecte todos los cables de alimentación de las tomas de alimentación eléctrica, extraiga la batería y desconecte los cables de interconexión.



危險

完成 FRU 更換之後，在開啟電腦的電源之前，請確定所有螺絲、彈簧及其他小零件都已歸位，沒有遺留在電腦內部。
若要確認這一點，請搖晃電腦，聽聽看是否有卡嗒的聲響。
金屬零件或儀錶的火花會造成電線短路。



危險

部分備用電池含有微量的鎳和鎘。請勿拆開備用電池、再充電、丟入火或水中，或使其形成短路。請按照當地法令或規定來棄置電池。
僅限使用零件清單中的電池。使用不適當的電池會導致電池起火或爆炸。



危險

電池套件含有微量的鎳。請勿拆開電池套件、丟入火或水中，或使其形成短路。請按照當地法令或規定來棄置電池套件。
更換電池套件時，僅限使用零件清單中的電池。使用不適當的電池會導致電池起火或爆炸。



危險

鋰電池會導致起火、爆炸或嚴重燒傷。請勿再充電、拔除其電極接頭、拆開、加熱超過 100°C (212°F)、焚燒，或讓電池組成物浸到水。請按照當地法令或規定來棄置電池。
僅限使用零件清單中的電池。使用不適當的電池會導致電池起火或爆炸。



如果 LCD 破裂導致 LCD 流出的液體沾到您的眼睛或手，請立即以清水沖洗沾染部位至少 15 分鐘。如果在清洗後出現該液體所造成的任何症狀，請就醫治療。



為避免電擊，請勿拆下轉換卡下面的塑膠護蓋。



雖然主電池的電壓很低，但短路或接地電池所產生的電流，仍足以使人燒傷或使可燃物質起火。



除非 FRU 允許以熱抽換來替換，否則請依下列方式將其移除：將電腦關機，拔除插座上所有電源線，移除電池包，並拔開任何交互連接的線材。

Chapter 2. Important service information

This chapter presents the following important service information that applies to all machine types supported by this manual:

- “Strategy for replacing FRUs” on page 19
 - “Strategy for replacing a hard disk drive” on page 20
 - “Important notice for replacing a system board” on page 20
 - “How to use error message” on page 20
- “Strategy for replacing FRUs for CTO, CMV, and GAV” on page 20
 - “Product definition” on page 20
 - “FRU identification for CTO, CMV, and GAV products” on page 21

Important:

- If the computer is equipped with both a hard disk drive and an mSATA solid-state drive, do not use the mSATA solid-state drive as a bootable device. The mSATA solid-state drive is used for the “cache” function only.
- Advise customers to contact the Lenovo® Customer Support Center if they need any assistance in obtaining or installing any software fixes, drivers, and UEFI BIOS downloads. Telephone numbers for Lenovo Support are available at <http://www.lenovo.com/support/phone>
- System Disassembly/Reassembly videos that show the FRU removals or replacements for the Lenovo authorized service technicians are available in the following support site: <http://www.lenovoservicetraining.com/ion/>

Strategy for replacing FRUs

Before replacing parts:

Ensure that all software fixes, drivers, and UEFI BIOS downloads are installed before replacing any FRUs listed in this manual.

After a system board is replaced, ensure that the latest UEFI BIOS is loaded to the system board before completing the service action.

To download and install software fixes, drivers, and UEFI BIOS, go to <http://www.lenovo.com/ThinkPadDrivers> and follow the instructions on the screen.

Use the following strategy to prevent unnecessary expense for replacing and servicing FRUs:

- If you are instructed to replace a FRU but the replacement does not correct the problem, reinstall the original FRU before you continue.
- Some computers have both a processor board and a system board. If you are instructed to replace either the processor board or the system board, and replacing one of them does not correct the problem, reinstall that board, and then replace the other one.
- If an adapter or a device consists of more than one FRU, any of the FRUs may be the cause of the error. Before replacing the adapter or device, remove the FRUs, one by one, to see if the symptoms change. Replace only the FRU that changed the symptoms.

Strategy for replacing a hard disk drive

Always try to run a low-level format operation before replacing a hard disk drive or a solid-state drive. This will cause all customer data on the hard disk drive or solid-state drive to be lost. Be sure that the customer has a current backup of the data before you perform this task.

Attention: The drive startup sequence in the computer you are servicing might have been changed. Be extremely careful during write operations such as copying, saving, or formatting. If you select an incorrect drive, data or programs can be overwritten.

If the computer is shipped with both an mSATA solid-state drive and a hard disk drive, the mSATA solid-state drive is used for the “cache” function and to support the Intel® Rapid Start Technology. We recommend that users do not replace the mSATA solid-state drive by themselves. Otherwise, the “cache” function will not work and the Intel Rapid Start Technology cannot be used any more.

Attention: Ensure that you partition the mSATA solid-state drive after installing it on the computer you are servicing. Otherwise, the mSATA solid-state drive will not function correctly. For instructions on partitioning the mSATA solid-state drive, go to <http://www.lenovo.com/support/msata-fru>.

Important notice for replacing a system board

Some components mounted on a system board are very sensitive. Improper handling of a system board can cause damage to those components, and may cause a system malfunction.

Attention: When handling a system board:

- Do not drop a system board or apply any excessive force to it.
- Avoid rough handling of any kind.
- Avoid bending a system board and hard pushing to prevent cracking at each Ball Grid Array (BGA) chipset.

How to use error message

Use the error codes displayed on the screen to diagnose failures. If more than one error code is displayed, begin the diagnosis with the first error code. Whatever causes the first error code might also cause false error codes. If no error code is displayed, see whether the error symptom is listed in the “Symptom-to-FRU Index”.

Strategy for replacing FRUs for CTO, CMV, and GAV

Product definition

Dynamic Configure To Order (CTO)

This provides the ability for a customer to configure a Lenovo solution from an eSite, and have this configuration sent to fulfillment, where it is built and shipped directly to the customer. The machine label, Product Entitlement Warehouse (PEW) and eSupport will load these products as the 4-digit MT and 3-digit model, where model = “CTO” (Example: 1829-CTO).

Custom Model Variant (CMV)

This is a unique configuration that has been negotiated between Lenovo and the customer. A unique 4-digit MT and 3-digit model is provided to the customer to place orders (Example: 1829-W15). A CMV is a special bid offering. Therefore, it is NOT generally announced.

- The MTM portion of the machine label is the 4-digit MT and 3-digit model, where model = “CTO” (Example: 1829-CTO). The PRODUCT ID portion of the machine label is the 4-digit MT and 3-digit CMV model (Example: 1829-W15).

- The PEW record is the 4-digit MT and 3-digit model, where model = “CTO” (Example: 1829-CTO).
- eSupport will show both the CTO and CMV machine type models (Example: 1829-CTO and 1829-W15 will be found on the eSupport site.)

General Announce Variant (GAV)

This is a standard model (fixed configuration). GAVs are announced and offered to all customers. The MTM portion of the machine label is a 4-digit MT and 3-digit model, where model = a “fixed part number”, not “CTO” (Example: 1829-F1U). Also, PEW and eSupport will list these products under the same fixed model number.

FRU identification for CTO, CMV, and GAV products

There are three information resources to identify which FRUs are used to support CTO, CMV, and GAV products. These sources are PEW and eSupport.

Using PEW

- PEW is the primary source for identifying FRU part numbers and FRU descriptions for the key commodities for CTO, CMV, and GAV products at an MT - serial number level. An example of key commodities are hard disk drives, system boards, microprocessors, liquid crystal displays (LCDs), and memory modules.
- Remember, all CTO and CMV products are loaded in PEW under the 4-digit MT and 3-digit model, where model = “CTO” (Example: 1829-CTO). GAVs are loaded in PEW under the 4-digit MT and 3-digit model, where model = a “fixed part number”, not “CTO” (Example: 1829-F1U).
- PEW can be accessed at the following Web site:
<http://www.lenovo.com/support/site.wss/document.do?Indocid=LOOK-WARNTY>
 Select Warranty lookup. Input the MT and the Serial number and the list of key commodities will be returned in the PEW record under COMPONENT INFORMATION.

Using eSupport

For key commodities (examples - hard disk drive, system board, microprocessor, LCD, and memory)

eSupport can be used to view the warranty status of key commodities built in a particular machine serial (this is the same record found in PEW). eSupport can be accessed at <http://www.lenovo.com/support>.

To view the warranty status of the key commodities on your computer, do the following:

1. Go to <http://www.lenovo.com/support>.
2. Click **Warranty & Services**.
3. Click **Check Warranty Status**.
4. On the Warranty Status Lookup page, click **Parts Lookup**.
5. Type your machine type and serial number, and then click **Submit**.

For the remaining FRUs (the complete list of FRUs at the MT model level)

eSupport also can be used to view the complete list of FRUs for a machine type and model. To view the complete list of FRUs, do the following:

1. Go to <http://www.lenovo.com/support>.
2. Click **Parts & Accessories**.
3. Provide your product information or click **Launch** to automatically identify your product.
4. Click **Product & Parts Detail**.
5. On the PRODUCT AND PARTS DETAIL page, click **Parts Detail** to view the complete list of FRUs.

Using the *Hardware Maintenance Manual*

For key commodities (examples - hard disk drive, system board, microprocessor, LCD, and memory)

Use the *Hardware Maintenance Manual* as a backup to PEW and eSupport to view the complete list of FRUs at the MT model level.

Chapter 3. General checkout

This chapter presents the following information:

- “What to do first” on page 23
- “Checkout guide” on page 24
- “Power system checkout” on page 26

Some descriptions in this chapter might not apply to your particular computer.

Before you go to the checkout guide, be sure to read the following important notes.

Important notes:

- **Only certified trained personnel should service the computer.**
- **Before replacing any FRU, read the entire page on removing or replacing FRUs.**
- **When you replace FRUs, it is recommended to use new nylon-coated screws.**
- **Be extremely careful during such write operations as copying, saving, or formatting.** Drives in the computer that you are servicing sequence might have been altered. If you select an incorrect drive, data or programs might be overwritten.
- **Replace a FRU only with another FRU of the correct model.** When you replace a FRU, ensure that the model of the machine and the FRU part number are correct. For the FRU part number, go to <http://www.lenovo.com/serviceparts-lookup>.
- **A FRU should not be replaced because of a single, unreproducible failure.** Single failures can occur for a variety of reasons that have nothing to do with a hardware defect, such as cosmic radiation, electrostatic discharge, or software errors. Consider replacing a FRU only when a problem recurs. If you suspect that a FRU is defective, clear the error log and run the test again. If the error does not recur, do not replace the FRU.
- **Be careful not to replace a nondefective FRU.**

What to do first

When you do return a FRU, you must include the following information in the parts exchange form or parts return form that you attach to it:

1. Name and phone number of service technician
2. Date of service
3. Date on which the machine failed
4. Date of purchase
5. Failure symptoms, error codes appearing on the display, and beep symptoms
6. Procedure index and page number in which the failing FRU was detected
7. Failing FRU name and part number
8. Machine type, model number, and serial number
9. Customer's name and address

Note: During the warranty period, the customer may be responsible for repair costs if the computer damage was caused by misuse, accident, modification, unsuitable physical or operating environment, or improper maintenance by the customer. Following is a list of some common items that are not covered under warranty and some symptoms that might indicate that the system was subject to stress beyond normal use.

Before checking problems with the computer, determine whether the damage is covered under the warranty by referring to the following list:

The following are not covered under warranty:

- LCD panel cracked from the application of excessive force or from being dropped
- Scratched (cosmetic) parts

- Distortion, deformation, or discoloration of the cosmetic parts
- Plastic parts, latches, pins, or connectors that have been cracked or broken by excessive force
- Damage caused by liquid spilled into the system
- Damage caused by the improper insertion of a PC Card or the installation of an incompatible card
- Fuses blown by attachment of a nonsupported device
- Forgotten computer password (making the computer unusable)
- Sticky keys caused by spilling a liquid onto the keyboard
- Use of an incorrect ac power adapter on laptop products

The following symptoms might indicate damage caused by nonwarranted activities:

- Missing parts might be a symptom of unauthorized service or modification.
- If the spindle of a hard disk drive becomes noisy, it may have been subject to excessive force, or dropped.

Checkout guide

Use the following procedures as a guide in identifying and correcting problems with the ThinkPad notebook computer.

Note: The diagnostic tests are intended to test only ThinkPad products. The use of non-ThinkPad products, prototype cards, or modified options can lead to false indications of errors and invalid system responses.

1. Identify the failing symptoms in as much detail as possible.
2. Verify the symptoms. Try to re-create the failure by running the diagnostic test or by repeating the operation.

Lenovo Solution Center

The Lenovo Solution Center program enables you to troubleshoot and resolve computer problems. It combines diagnostic tests, system information collection, security status, and support information, along with hints and tips for maximum system performance.

The Lenovo Solution Center program is available for download at <http://www.lenovo.com/diags>.

To run the Lenovo Solution Center program, go to Control Panel and click **System and Security** → **Lenovo - System Health and Diagnostics**, and then follow the instructions on the screen.

For more information about the Lenovo Solution Center program, refer to the help information system of the program.

Quick test programs

You can run quick test programs to troubleshoot and resolve computer problems, especially when the computer does not have the Lenovo Solution Center program installed.

Lenovo provides the following quick test programs:

- **Lenovo Hard Drive Quick Test:** Use this program to troubleshoot and resolve internal storage problems.
- **Lenovo Memory Quick Test:** Use this program to troubleshoot and resolve memory module problems.

The quick test programs are applicable on the following operating systems:

- Microsoft® Windows® 8
- Microsoft Windows 7
- Microsoft Windows XP
- Microsoft Windows Server® 2003

- Microsoft Windows Server 2008

To download and install a quick test program, go to <http://www.lenovo.com/diags>, and follow the instructions on the Web site.

To run a test using a quick test program, do the following:

1. Go to the C:\SWTOOLS\ldiag directory.
2. Double-click the gui_lsc_lite.exe file.
3. When the **User Account Control** window opens, click **Yes**.
4. Select the device class to be tested.
5. Select the devices to be tested.
6. Select the tests to be performed.
7. Follow the instructions on the screen to start the test. When a problem is detected, information messages are displayed. Refer to the messages to troubleshoot the problem.

UEFI diagnostic program

A UEFI diagnostic program is preinstalled on the computer. It enables you to test memory modules and internal storage devices, view system information, and check and recover bad sectors on internal storage devices.

To run the UEFI diagnostic program, do the following:

1. Turn on the computer. If the computer cannot be turned on, go to “Power system checkout” on page 26, and check the power sources. If an error code is displayed, go to “Symptom-to-FRU index” on page 34 for error code descriptions and troubleshooting hints.
2. When the ThinkPad logo is displayed, repeatedly press and release the F10 key. The main screen of the UEFI diagnostic program is displayed.
3. Follow the instructions on the screen to use the program.

Table 1. Items on the main screen of the UEFI diagnostic program

Tests	Tools
<ul style="list-style-type: none"> • Quick Memory Test • Quick Storage Device Test • Exit Application 	<ul style="list-style-type: none"> • System Information • Recover Bad Sectors Tool

Bootable diagnostic programs

If the computer you are servicing is not installed with the UEFI diagnostic program, you can download a bootable diagnostic program from the Lenovo Support Web site. The bootable diagnostic programs enable you to test computer memory and internal storage devices, view system information, and check and recover the internal storage devices. To use the bootable diagnostic programs, you can create a bootable diagnostic medium on a USB device or CD.

To create a bootable diagnostic medium, do the following:

1. Go to <http://www.lenovo.com/diags>.
2. Click **Lenovo Bootable Diagnostics**.
3. Follow the instructions on the Web site to create a bootable diagnostic medium on a USB device or CD.

To use the diagnostic medium you have created, do one of the following:

- If you have created the bootable diagnostic medium on a USB device, do the following:
 1. Attach the USB device to the computer.
 2. Turn on the computer. If the computer cannot be turned on, go to “Power system checkout” on page 26, and check the power sources. If an error code is displayed, go to “Symptom-to-FRU index” on page 34 for error code descriptions and troubleshooting hints.
 3. When the ThinkPad logo is displayed, repeatedly press and release the F12 key. When the Boot Menu window opens, release the F12 key.
 4. Use the arrow keys to select **USB HDD** and then press Enter. The diagnostic program will be launched automatically.
 5. Follow the instructions on the screen to use the diagnostic program.
- If you have created the bootable diagnostic medium on a CD, do the following:
 1. Turn on the computer. If the computer cannot be turned on, go to “Power system checkout” on page 26, and check the power sources. If an error code is displayed, go to “Symptom-to-FRU index” on page 34 for error code descriptions and troubleshooting hints.
 2. Insert the CD into the optical drive.
 3. Restart the computer.
 4. When the ThinkPad logo is displayed, repeatedly press and release the F12 key. When the Boot Menu window opens, release the F12 key.
 5. Use the arrow keys to select **ATAPI CDx** (x: 0, 1, ...) and then press Enter. The diagnostic program will be launched automatically.
 6. Follow the instructions on the screen to use the diagnostic program.

Power system checkout

To verify a symptom, do the following:

1. Turn off the computer.
2. Remove the battery pack.
3. Connect the ac power adapter.
4. Check that power is supplied when you turn on the computer.
5. Turn off the computer.
6. Disconnect the ac power adapter and install the charged battery pack.
7. Check that the battery pack supplies power when you turn on the computer.

If you suspect a power problem, see the appropriate one of the following power supply checkouts:

- “Checking the ac power adapter” on page 26
- “Checking operational charging” on page 27
- “Checking the battery pack” on page 27
- “Checking the backup battery” on page 28

Checking the ac power adapter

If your computer fails only when the ac power adapter is used, use the instructions in this topic.

- If the power problem occurs only when the docking station or the port replicator is used, replace the docking station or the port replicator.
- If the power-on indicator does not turn on, check the power cord of the ac power adapter for correct continuity and installation.
- If the computer does not charge during operation, go to “Checking operational charging” on page 27.

To check the ac power adapter, do the following:

1. Unplug the ac power adapter cable from the computer.

2. Measure the output voltage at the plug of the ac power adapter cable. See the following illustration:

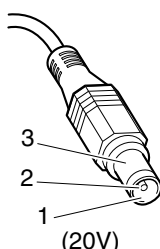

Pin	Voltage (V dc)
1	+20
2	0
3	Ground

Note: Output voltage across pin 2 of the ac power adapter might differ from the one you are servicing.

3. If the voltage is not correct, replace the ac power adapter.
4. If the voltage is acceptable, replace the system board.

Note: Noise from the ac power adapter does not always indicate a defect.

Checking operational charging

To check whether the battery charges properly during operation, use a discharged battery pack or a battery pack that has less than 50% of the total power remaining when installed in the computer.

Perform operational charging. If the battery status indicator or icon does not turn on, remove the battery pack and let it return to room temperature. Reinstall the battery pack. If the charge indicator or icon still does not turn on, replace the battery pack.

If the charge indicator still does not turn on, replace the system board. Then reinstall the battery pack. If it is still not charged, go to the next section.

Checking the battery pack

The battery status icon in the Windows notification area displays the percentage of battery power remaining.

To check for detailed battery status information, do the following:

- For Windows 7: Open the Power Manager program and click the **Battery** tab.
- For Windows 8: Open the Lenovo Support program and click **Battery Health**, or open the Lenovo Settings program and click **Power**.

Note: If the battery pack becomes hot, it may not be able to charge. Remove it from the computer and leave it at room temperature for a while. After it cools down, reinstall and recharge it.

To check the battery pack, do the following:

1. Power off the computer.
2. Remove the battery pack and measure the voltage between battery terminals 1 (+) and 7 (-). See the following illustration:

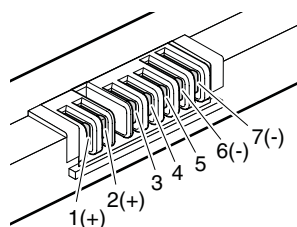

Terminal	Voltage (V dc)
1	+ 0 to + 16.8
7	Ground (-)

3. If the voltage is less than +11.0 V dc, the battery pack has been discharged.

Note: Recharging will take at least 3 hours, even if the indicator does not turn on.

If the voltage is still less than +11.0 V dc after recharging, replace the battery.

4. If the voltage is more than +11.0 V dc, measure the resistance between battery terminals 5 and 7. The resistance must be 4 to 30 K Ω . If the resistance is not correct, replace the battery pack. If the resistance is correct, replace the system board.

Checking the backup battery

Do the following:

1. Power off the computer, and unplug the ac power adapter from it.
2. Turn the computer upside down.
3. Remove the battery pack (see “1010 Battery pack” on page 56).
4. Remove the backup battery (see “1060 Backup battery” on page 65).
5. Measure the voltage of the backup battery. See the following illustration.

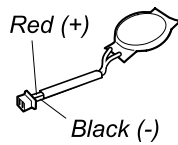

Wire	Voltage (V dc)
Red	+2.5 to +3.2
Black	Ground

- If the voltage is correct, replace the system board.
- If the voltage is not correct, replace the backup battery.
- If the backup battery discharges quickly after replacement, replace the system board.

Chapter 4. Related service information

This chapter presents the following information:

- “Restoring the factory contents by using Recovery Disc Set” on page 29
- “Using the Windows recovery programs on the Windows 8 operating system” on page 30
- “Passwords” on page 31
- “Power management” on page 33
- “Symptom-to-FRU index” on page 34

Service Web site:

When the latest maintenance diskette and the system program service diskette become available, they will be posted on <http://www.lenovo.com/support>.

Restoring the factory contents by using Recovery Disc Set

When the hard disk drive or solid-state drive is replaced because of a failure, no product recovery program is on the new drive. In this case, you must use the recovery disc set for the computer. Order the recovery disc set and the drive at the same time so that you can recover the new drive with the preinstalled software when they arrive. For information on which discs to order, go to <http://www.lenovo.com/serviceparts-lookup>.

The recovery disc set consists of the user instructions and the following set of DVDs to restore the computer to the original factory configuration.

- *Operating System Recovery Disc* (one disc): This disc restores the Microsoft® Windows operating system. Use this disc to start the recovery process.
- *Applications and Drivers Recovery Disc* (one or more discs): This disc restores the preinstalled applications and drivers on the computer.
- *Supplemental Recovery Disc*: This disc contains additional content, such as updates to the software that was preinstalled on the computer. Not all recovery disc sets come with a *Supplemental Recovery Disc*.

Notes:

- You must have a DVD drive to use the recovery discs. If you do not have an internal DVD drive, you can use an external USB DVD drive.
- During the recovery process, all data on the drive will be deleted. If possible, copy any important data or personal files that you want to keep onto removable media or a network drive before you start the recovery process.

To restore the computer to the original factory configuration using the recovery disc set, do the following:

Note: Recovery can take one to two hours to complete. The length of time depends on the method you use. If you use recovery discs, the recovery process will take about two hours.

1. Make the CD/DVD drive the first startup device in the startup sequence using the following procedure:
 - a. Press and hold down the F1 key, and then turn on the computer. When the logo screen is displayed or when you hear repeating beeps, release the F1 key. The ThinkPad Setup program opens.
 - b. Use the arrow keys to select **Startup → Boot**.
 - c. Select the CD/DVD drive as the **1st Boot Device**.
2. Insert the *Operating System Recovery Disc* into the DVD drive.
3. Press F10 to save the ThinkPad Setup program configuration changes. Follow the instructions on the screen to begin the recovery process.
4. Select your language and click **Next**.

5. Read the license. If you agree with the terms and conditions, select **I accept these terms and conditions** and then click **Next**. If you do not agree with the terms and conditions, follow the instructions on the screen.
6. Click **Yes** in the displayed window to begin the operating system recovery process.
7. Insert the *Applications and Drivers Recovery Disc* when prompted and then click **OK** to begin the process of recovering applications and drivers.
8. If you have a *Supplemental Recovery Disc*, insert it when prompted and click **Yes**. If you do not have a *Supplemental Recovery Disc*, click **No**.
9. When all of the data has been copied from the last disc in the set and has been processed, remove the disc and restart the computer.

Note: The rest of the recovery process is fully automated and no action from you is required. The computer will restart into the Microsoft Windows desktop several times and you might experience periods when no activity is apparent on the screen for several minutes at a time. This is normal.

10. When the recovery process is complete, the Set Up Windows screen is displayed. Follow the instructions on the screen to complete the Windows setup.
11. After you have completed the Windows setup, you might want to restore the original startup sequence. Start the ThinkPad Setup program and then press F9 to restore the default settings. Press F10 to save changes and exit the ThinkPad Setup program.

Note: After restoring a drive to the factory default settings, you might need to reinstall some device drivers.

Using the Windows recovery programs on the Windows 8 operating system

The computer you are servicing might come with built-in recovery programs provided by the Windows 8 operating system. You can use those programs to refresh or restore the computer.

Refreshing the computer

If the computer you are servicing does not perform well and the problem might be caused by a recently installed program, you can refresh the computer without losing the customers' personal files or changing the settings.

Attention: All the personal files and settings will be deleted after you reset the computer to the factory default settings. Ensure that the user has made a backup copy of all the data before resetting the computer to the factory default settings.

To reset your computer, do the following:

1. Move your cursor to the bottom-right corner of the screen to bring up the charms. Click **Settings** → **Change PC settings** → **General**.
2. In the **Refresh your PC without affecting your files** section, click **Get started**.

Resetting the computer to factory default settings

You can reset the computer to the factory default settings. During the process, the operating system and all programs that are shipped with the computer will be reinstalled.

Attention: If you reset the computer, all the personal files and settings will be deleted. To avoid data loss, ensure that the customer has made a backup copy of all the data.

To reset your computer, do the following:

1. Move your cursor to the bottom-right corner of the screen to bring up the charms. Click **Settings** → **Change PC settings** → **General**.

2. In the **Remove everything and reinstall Windows** section, click **Get started**.

Advanced startup options

Advanced startup options enable you to change the startup settings of the Windows operating system, start the computer from an external device, or restore the Windows operating system from a system image.

To use the advanced startup options, do the following:

1. Move your cursor to the bottom-right corner of the screen to bring up the charms. Click **Settings** → **Change PC settings** → **General**.
2. In the **Advanced startup** section, click **Restart now** → **Troubleshoot** → **Advanced options**.
3. Restart the computer following the instructions on the screen.

For more details about the Windows recovery solutions, refer to the help information system of the Windows 8 operating system.

Passwords

As many as three passwords might be needed for a ThinkPad notebook computer: the power-on password, the hard disk password, and the supervisor password.

If any of these passwords has been set, a prompt for it will be displayed on the screen whenever the computer is turned on. The computer does not start until the password is entered.

Note: If only a supervisor password is set, the password prompt will not be displayed when the operating system is started.

Power-on password

A power-on password protects the system from being turned on by an unauthorized person. The password must be entered before an operating system can be booted. For instructions on how to remove the power-on password, see “How to remove the power-on password” on page 32.

Hard-disk password

There are two hard disk passwords:

- User hard disk password - for the user
- Master hard disk password - for the system administrator, who can use it to get access to the hard disk even if the user has changed the user hard disk password.

Note: There are two modes for the hard disk password: **User only** and **Master + User**. The **Master + User** mode requires two hard disk passwords; the system administrator enters both in the same operation. The system administrator then provides the user hard disk password to the system user.

Attention: If the user hard disk password has been forgotten, check whether a master hard disk password has been set. If a master hard disk password has been set, it can be used to access the hard disk drive. If no master hard disk password is available, neither Lenovo nor Lenovo authorized service technicians provide any services to reset either the user hard disk password or the master hard disk password, or to recover data from the hard disk drive. The hard disk drive can be replaced for a scheduled fee.

For instructions on how to remove the hard disk password, see “How to remove the hard-disk password” on page 32.

Supervisor password

A supervisor password protects the system information stored in the ThinkPad Setup program. The user must enter the supervisor password in order to get access to the ThinkPad Setup program and change the system configuration.

Attention: If the supervisor password has been forgotten and cannot be made available to the service technician, there is no service procedure to reset the password. The system board must be replaced for a scheduled fee.

How to remove the power-on password

To remove the power-on password, do the following:

If no supervisor password has been set, do the following to remove the power-on password:

1. Turn off the computer and disconnect the ac power adapter.
2. Remove the battery pack. For instructions on how to remove the battery pack, see “1010 Battery pack” on page 56.
3. Remove the backup battery. For instructions on how to remove the backup battery, see “1060 Backup battery” on page 65.
4. Connect the ac power adapter. Turn on the computer and wait until the POST ends. After the POST ends, the password prompt will not be displayed. The power-on password has been removed.
5. Reinstall the backup battery and the battery pack.

If a supervisor password has been set and is known to the service technician, do the following to remove the power-on password:

1. Turn on the computer.
2. When the ThinkPad logo is displayed, immediately press F1.
3. Type the supervisor password to enter the ThinkPad Setup program.
4. Select **Security**.
5. Select **Password**.
6. Select **Power-On Password**.
7. Type the current supervisor password in the **Enter Current Password** field. Then, leave the **Enter New Password** field blank, and press Enter twice.
8. In the Changes have been saved window, press Enter.
9. Press F10 to save changes and exit the ThinkPad Setup program.

How to remove the hard-disk password

Attention: If **User only** mode is selected and the user hard disk password has been forgotten and cannot be made available to the service technician, neither Lenovo nor Lenovo authorized service technicians provide any services to reset the user hard disk password, or to recover data from the hard disk drive. The hard disk drive can be replaced for a scheduled fee.

To remove a user hard disk password that has been forgotten, when the supervisor password and the master hard disk password are known, do the following:

1. Turn on the computer.
2. When the ThinkPad logo is displayed, immediately press F1 to enter the ThinkPad Setup program.
3. Select **Security**.
4. Select **Password**.
5. Select **Hard-disk x password**, where x is the letter of the hard disk drive. A pop-up window opens.

6. Select **Master HDP**, where HDP stands for hard disk password.
7. Type the current master hard disk password in the **Enter Current Password** field. Then, leave the **Enter New Password** field blank, and press Enter twice.
8. Press F10 to save changes and exit the ThinkPad Setup program. The user hard disk password and the master hard disk password have been removed.

Power management

To reduce power consumption, the computer has three power management modes: screen blank, sleep, and hibernation.

Screen blank mode (for the Windows 7 operating system only)

If the time set on the “Turn off monitor” timer in the operating system expires, the LCD backlight turns off.

To put the computer into screen blank mode, do the following:

1. Right-click the battery gauge in the task bar.
2. Select **Power off display (keep current power plan)**.

To end screen blank mode and resume normal operation, press any key.

Sleep mode

When the computer enters sleep mode, the following events occur in addition to what occurs in screen blank mode:

- The LCD is powered off.
- The hard disk drive or the solid-state drive is powered off.
- The microprocessor stops.

To enter sleep mode, press Fn+F4.

In certain circumstances, the computer goes into sleep mode automatically:

- After a period of inactivity specified in power plan settings
- When the battery indicator blinks orange, indicating that the battery power is low

To cause the computer to return from sleep mode and resume operation, do one of the following:

- Press the Fn key.
- Open the LCD cover.
- Turn on the power switch.

Also, in either of the following events, the computer automatically returns from sleep mode and resumes operation:

- The ring indicator (RI) is signaled by a serial device or a PC Card device. (*does not support the ring indicator (RI) resume by PC Card device.*)
- The time set on the resume timer elapses.

Note: The computer does not accept any input immediately after it enters sleep mode. Wait a few seconds before taking any action to reenter operation mode.

Hibernation mode

In hibernation mode, the following occurs:

- The system status, RAM, VRAM, and setup data are stored on the hard disk.
- The system is powered off.

Note: If the computer enters the hibernation mode while it is docked to the docking station, do not undock it before resuming normal operation. If you do undock it and then try to resume normal operation, you will get an error message, and you will have to restart the system.

If you have defined one of the following actions as the event that causes the system to go into hibernation mode, perform that action.

- Closing the lid.
- Pressing the power button.
- Pressing Fn+F4 keys.

Also, the computer goes into hibernation mode automatically after a period of inactivity specified in power plan settings.

When the power is turned on, the computer returns from hibernation mode and resumes operation. The hibernation file in the boot record on the hard disk drive is read, and system status is restored from the hard disk drive.

Symptom-to-FRU index

This section contains following information:

- “Numeric error codes” on page 35
- “Error messages” on page 36
- “Beep symptoms” on page 36
- “No-beep symptoms” on page 37
- “LCD-related symptoms” on page 37
- “Intermittent problems” on page 37
- “Undetermined problems” on page 38

The symptom-to-FRU index in this section lists symptoms and errors and their possible causes. The most likely cause is listed first, in boldface type.

Note: Do the FRU replacement or other actions in the sequence shown in the column headed “FRU or action, in sequence.” If replacing a FRU does not solve the problem, put the original part back in the computer. Do not replace a nondefective FRU.

This index can also help you determine, during regular servicing, what FRUs are likely to need to be replaced next.

A numeric error is displayed for each error detected in POST or system operation. In the displays, **n** can be any number.

If no numeric code is displayed, check the narrative descriptions of symptoms. If the symptom is not described there, go to “Intermittent problems” on page 37.

Note: For a device not supported by diagnostic codes in the ThinkPad notebook computers, see the manual for that device.

Numeric error codes

Table 2. Numeric error codes

Symptom or error	FRU or action, in sequence
0177 Bad SVP data, stop POST task—The checksum of the supervisor password in the EEPROM is not correct.	System board.
0183 Bad CRC of Security Settings in EFI Variable. Enter the ThinkPad Setup program.	<ol style="list-style-type: none"> 1. Run the ThinkPad Setup program, and then save current setting by pressing F10. 2. System board.
0187 EAIA data access error—The access to EEPROM is failed.	System board.
0188 Invalid RFID Serialization Information Area.	System board.
0189 Invalid RFID configuration information area—The EEPROM checksum is not correct.	System board.
0190 Critical low-battery error	<ol style="list-style-type: none"> 1. Charge the battery pack. 2. Battery pack.
0191 System Security—Invalid Remote Change requested.	<ol style="list-style-type: none"> 1. Run the ThinkPad Setup program, and then save current setting by pressing F10. 2. System board.
0199 System Security— Security password retry count exceeded.	<ol style="list-style-type: none"> 1. Run the ThinkPad Setup program, and then save the current setting by pressing F10. 2. System board.
0251 System CMOS checksum bad - Default configuration used.	<ol style="list-style-type: none"> 1. Charge the backup battery for more than 8 hours by connecting the ac adapter. 2. Replace the backup battery and run ThinkPad Setup to reset the time and date.
0253 EFI Variable Block Data was destroyed.	
0271 Real-Time Clock Error. Check Date and Time settings.	Run ThinkPad Setup to reset the time and date
1802 Unauthorized network card is plugged in—Turn off and remove the miniPCI network card.	<ol style="list-style-type: none"> 1. Remove Mini PCI network card. 2. System board.
1820 More than one external fingerprint reader is attached. Power off and remove all but the reader that you set up within your main operating system.	Remove all but the reader that you set up for the authentication.
2000 ThinkVantage® Active Protection sensor diagnostics failed.	System board
2100 Detection error on HDD0 (Main HDD)	<ol style="list-style-type: none"> 1. Reseat the hard disk drive. 2. Main hard disk drive. 3. System board.
2101 Detection error on HDD1 (Ultrabay HDD)	<ol style="list-style-type: none"> 1. Reseat the hard disk drive. 2. Ultrabay® hard disk drive. 3. System board.

Table 2. Numeric error codes (continued)

Symptom or error	FRU or action, in sequence
2102 Detection error on HDD2 (Mini SATA)	<ol style="list-style-type: none"> 1. Reseat the Mini SATA device. 2. Mini SATA device. 3. System board.
2110 Read error on HDD0 (Main HDD)	<ol style="list-style-type: none"> 1. Reseat the hard disk drive. 2. Main hard disk drive. 3. System board.
2111 Read error on HDD1 (Ultrabay HDD)	<ol style="list-style-type: none"> 1. Reseat the hard disk drive. 2. Ultrabay hard disk drive. 3. System board.
2112 Read error on HDD2 (Mini SATA)	<ol style="list-style-type: none"> 1. Reseat the Mini SATA device. 2. Mini SATA device. 3. System board.
2200 Machine Type and Serial Number are invalid.	System board.
2201 Machine UUID is invalid	System board.

Error messages

Table 3. Error messages

Symptom or error	FRU or action, in sequence
Fan error.	<ol style="list-style-type: none"> 1. Fan. 2. Thermal grease. 3. System board.
Thermal sensing error.	System board.
The battery installed is not supported by this system and will not charge. Please replace the battery with the correct Lenovo battery for this system. Press the ESC key to continue.	Replace the battery.

Beep symptoms

Table 4. Beep symptoms

Symptom or error	FRU or action, in sequence
Four cycles of four short beeps	System board
Five short beeps, pause, and five more short beeps	System board
One short beep, pause, three short beeps, pause, three more short beeps, pause, and one short beep	<ol style="list-style-type: none"> 1. Memory module. 2. System board.
Three short beeps, pause, one short beep, pause, one more short beep, pause, and three short beeps	Remove the installed PCI devices.
Five short beeps	System board
One long and two short beeps	System board

No-beep symptoms

Table 5. No-beep symptoms

Symptom or error	FRU or action, in sequence
No beep, power-on indicator on, LCD blank, and no POST.	<ol style="list-style-type: none"> 1. Ensure that every connector is connected tightly and correctly. 2. Memory module. 3. System board.
No beep, power-on indicator on, and LCD blank during POST.	<ol style="list-style-type: none"> 1. Reseat memory module. 2. System board.
The power-on password prompt appears.	A power-on password or a supervisor password is set. Type the password and press Enter .
The hard-disk password prompt appears.	A hard-disk password is set. Type the password and press Enter .

LCD-related symptoms

Important: The TFT LCD for the notebook computer contains many thin-film transistors (TFTs). The presence of a small number of dots that are missing, discolored, or always lighted is characteristic of TFT LCD technology, but excessive pixel problems can cause viewing concerns.

If the LCD you are servicing has two or less visible defective pixels, it should not be considered faulty. However, if the LCD has three or more visible defective pixels, it will be deemed as defective by Lenovo and it should be replaced.

Notes:

- This policy applies to all ThinkPad notebook computers purchased on 1 January, 2008 or later.
- Lenovo will not provide replacement if the LCD is within specification as we cannot guarantee that any replacement LCD will have zero pixel defects.
- One pixel consists of R, G, B sub-pixels.

Table 6. LCD-related symptoms

Symptom or error	FRU or action, in sequence
No beep, power-on indicator on, and a blank LCD during POST.	System board.
<ul style="list-style-type: none"> • LCD backlight not working. • LCD too dark. • LCD brightness cannot be adjusted. • LCD contrast cannot be adjusted. 	<ol style="list-style-type: none"> 1. Reseat the LCD connectors. 2. LCD assembly. 3. System board.
<ul style="list-style-type: none"> • LCD screen unreadable. • Characters missing pixels. • Screen abnormal. • Wrong color displayed. 	<ol style="list-style-type: none"> 1. See important note for “LCD-related symptoms.” 2. Reseat all LCD connectors. 3. LCD assembly. 4. System board.
Horizontal or vertical lines displayed on LCD.	LCD assembly.

Intermittent problems

Intermittent system hang problems can be due to a variety of causes that have nothing to do with a hardware defect, such as cosmic radiation, electrostatic discharge, or software errors. FRU replacement should be considered only when a problem recurs.

Undetermined problems

If the diagnostic tests did not identify the device that has failed, if wrong devices are installed, or if the system simply is not operating, follow these procedures to isolate the failing FRU (do not isolate FRUs that have no defects).

Verify that all attached devices are supported by the computer.

Verify that the power supply being used at the time of the failure is operating correctly. (See “Power system checkout” on page 26.)

1. Turn off the computer.
2. Visually check each FRU for damage. Replace any damaged FRU.
3. Remove or disconnect all of the following devices:
 - a. Non-ThinkPad devices
 - b. Devices attached to the docking station or the port replicator
 - c. Printer, mouse, and other external devices
 - d. Battery pack
 - e. Hard disk drive
 - f. External diskette drive or optical drive
 - g. Memory module in SLOT-1 (To locate SLOT-1, see “1030 Memory module” on page 59.)
 - h. Express Card and media card
4. Turn on the computer.
5. Determine whether the problem has been solved.
6. If the problem does not recur, reconnect the removed devices one at a time until you find the failing FRU.
7. If the problem remains, replace the following FRUs one at a time (do not replace a nondefective FRU):
 - a. System board
 - b. LCD assembly

Chapter 5. Status indicators

This chapter presents the system status indicators that show the status of the computer.

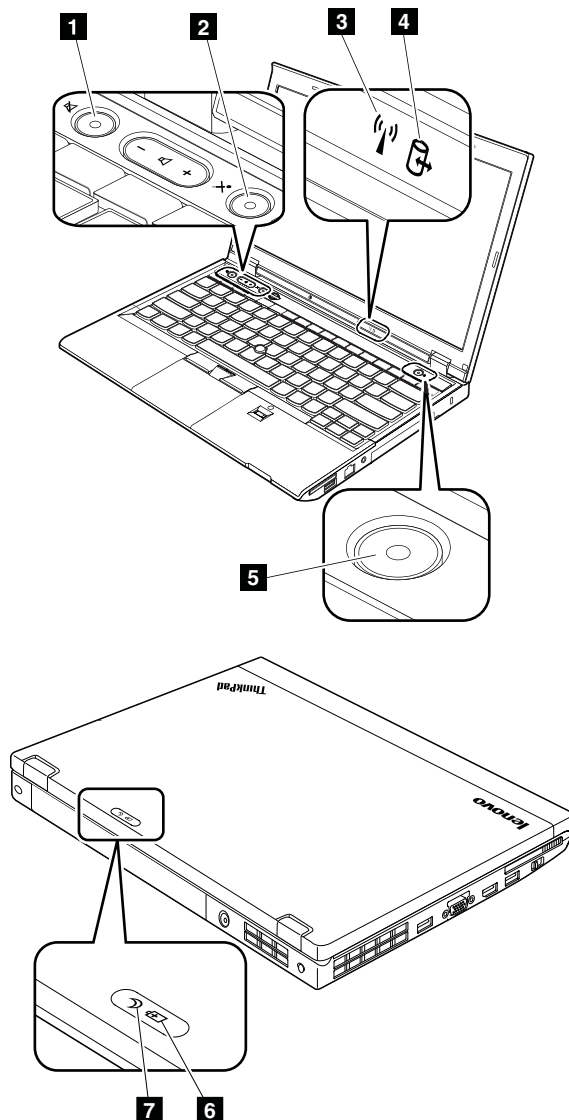

Table 7. Status indicators







Indicator	Meaning
1 Speaker mute indicator 	Orange: The speakers are on mute. To mute or unmute the speakers, press the speaker mute button.
2 Microphone mute indicator 	Orange: The microphones are on mute. By default, when the microphones are on mute, none of the recording devices is available.

Table 7. Status indicators (continued)

Indicator	Meaning
<p>3 Wireless LAN, WAN, Bluetooth or WiMAX status indicator</p> 	<p>Green: The wireless LAN, WAN, Bluetooth, or WiMAX feature is on.</p> <p>Blinking green: Data is being transmitted.</p>
<p>4 Device access status indicator</p> 	<p>Green: The hard disk drive, solid-state drive, or mSATA solid-state drive is reading or writing data.</p>
<p>5 Power-on indicator</p> 	<p>The power button stays lit whenever the computer is on, blinks when the computer is in sleep mode, and is off when the computer is turned off.</p>
<p>6 Battery status indicator</p> 	<p>Steady green: It indicates one of the following:</p> <ul style="list-style-type: none"> • The battery charge level is 80% or higher. • The battery charge level is between 20% and 80%, and the battery is not charging. <p>Slow blinking green: The battery charge level is between 20% and 80%, and the battery is charging.</p> <p>Steady orange: The battery charge level is between 5% and 20%, and the battery is not charging.</p> <p>Slow blinking orange: The battery charge level is between 5% and 20%, and the battery is charging.</p> <p>Fast blinking orange: The battery charge level is lower than 5%.</p> <p>Quick blinking orange: An error has occurred in the battery.</p> <p>Blinking three times: The ac power adapter is being attached to the computer.</p> <p>Off: The battery pack is detached or the computer is powered off.</p> <p>Note: If the computer is operating on battery power, the battery status indicator does not work while the computer is turned off or is in sleep mode or hibernation mode.</p>
<p>7 Sleep status indicator</p> 	<p>Green: The computer is in sleep mode.</p> <p>Blinking green: The computer is entering sleep mode or hibernation mode, or is resuming normal operation.</p>

Chapter 6. Fn key combinations

The following table describes the functions of Fn key combinations.

Table 8. Fn key combinations

Key combination	Description
Fn+F3	Locks the computer.
Fn+F4	Puts the computer into sleep mode. To return to normal operation, press the Fn key only. Notes: <ul style="list-style-type: none">• To use the Fn+F4 key combination, you must have the ThinkPad Power Management Driver installed on the computer.• If you want to use the combination to put the computer into hibernation mode, change the power plan settings.
Fn+F5	Enables or disables the built-in wireless networking features. Notes: If you want to use Fn+F5 to enable or disable the wireless features, the following device drivers must be installed on the computer beforehand: <ul style="list-style-type: none">• Power Management Driver• On Screen Display Utility• Wireless device drivers
Fn+F6	<ul style="list-style-type: none">• For Windows 7: Opens the Communications settings window, in which you can preview your video image, take a snapshot of your current image, and change the camera and audio settings.• For Windows 8: Starts the Lenovo Settings program, which enables you to change the camera and audio settings.
Fn+F7	Switches between the computer display and an external monitor. Note: You also can use the Windows+P combination to switch between the computer display and an external monitor.
Fn+F8	The computer display becomes dimmer.
Fn+F9	The computer display becomes brighter.
Fn+F10	Previous track/scene
Fn+F11	Play or pause
Fn+F12	Next track/scene
Fn+Spacebar	Controls the keyboard backlight and the ThinkLight® light. <ul style="list-style-type: none">• Press once: Turn on the keyboard backlight to low brightness level.• Press again: Adjust the keyboard backlight to high brightness level.• Press the third time: Turn off the keyboard backlight and turn on the ThinkLight light.• Press the fourth time: Turn off the ThinkLight light. Note: If the computer you are servicing does not have a backlit keyboard, the Fn+Spacebar combination controls only the ThinkLight light.
Fn+B	Has the same function as the Break key on a conventional keyboard.
Fn+K	Has the same function as the ScrLK key on a conventional keyboard.
Fn+P	Has the same function as the Pause key on a conventional keyboard.
Fn+S	Has the same function as the SysRq key on a conventional keyboard.

Chapter 7. Locations

This chapter introduces the locations of the computer hardware components.

Locating computer controls, connectors, and indicators

This topic introduces the locations of the computer controls, connectors, and indicators.

Front view

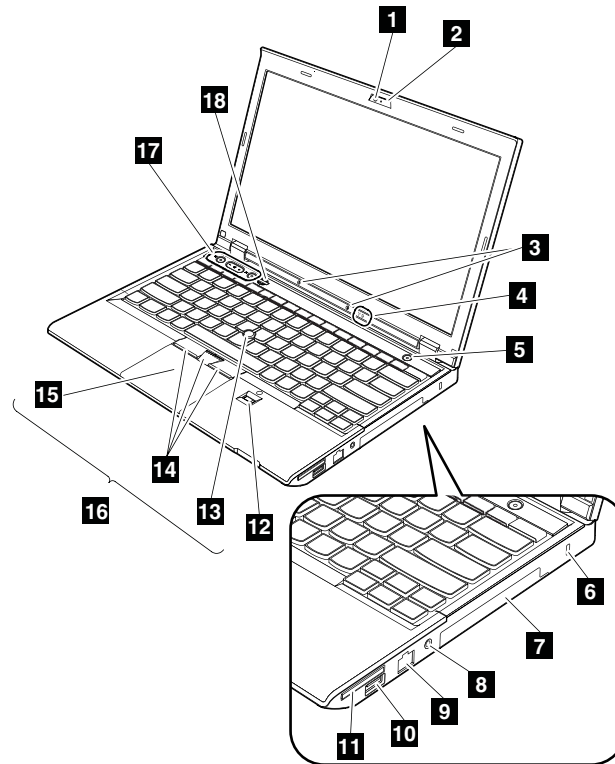

- | | |
|---|---|
| 1 Integrated camera | 10 Always On USB connector |
| 2 ThinkLight light | 11 Media card reader slot |
| 3 Built-in microphones | 12 Fingerprint reader (on some models) |
| 4 Status indicators (see Chapter 5 “Status indicators” on page 39) | 13 TrackPoint pointing stick |
| 5 Power button | 14 TrackPoint buttons |
| 6 Security keyhole | 15 Touch pad |
| 7 Hard disk drive or solid-state drive | 16 UltraNav® pointing device |
| 8 Combo audio jack | 17 Volume control buttons |
| 9 Ethernet connector | 18 Black button |

Rear view

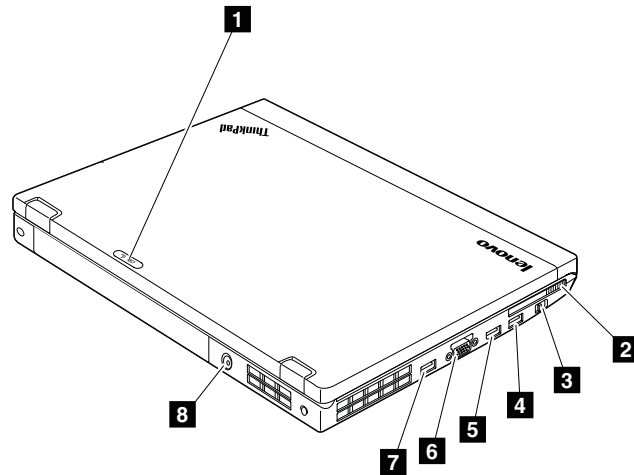

1 Status indicators (see Chapter 5 “Status indicators” on page 39)

2 ExpressCard slot

3 Wireless radio switch

4 USB 3.0 connector

5 Mini DisplayPort connector

6 Video graphics array (VGA) connector

7 USB 3.0 connector

8 ac power connector

Bottom view

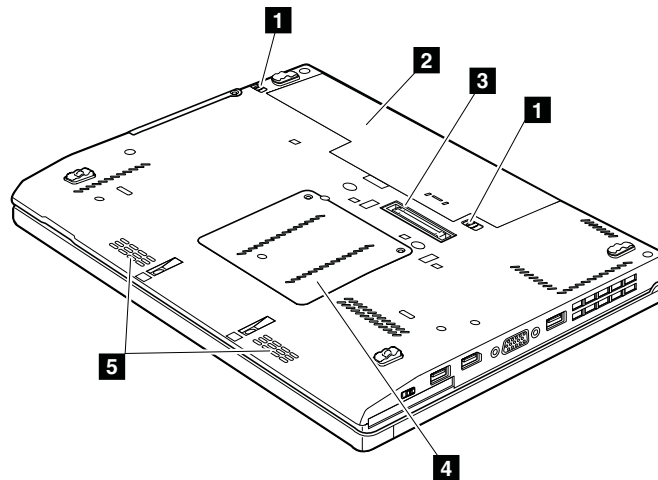

1 Battery pack latches

2 Battery pack

3 Docking station connector

4 Memory module slot

5 Built-in speakers

Locating FRUs and CRUs

This topic introduces the following service parts:

- “Major FRUs and CRUs” on page 46
- “LCD FRUs and CRUs” on page 48

Notes:

- Each FRU is available for all types or models, unless otherwise specified.
- **CRU statement for customers:**

You can resolve some problems with your product with a replacement part you can install yourself, called a “Customer Replaceable Unit” or “CRU.” Some CRUs are designated as self-service CRUs and others are designated as optional-service CRUs. *Installation of self-service CRUs is your responsibility. For optional-service CRUs, you can either install the CRU yourself or you can request that a Service Provider install the CRU according to the warranty service for your product.* If you intend on installing the CRU, Lenovo will ship the CRU to you. CRU information and replacement instructions are shipped with your product and are available from Lenovo at any time upon request. You can find a list of CRUs for your product in this *Hardware Maintenance Manual*. An electronic version of this manual can be found at <http://www.lenovo.com/support>. Click **User Guides & Manuals** and then follow the on-screen instructions to find the manual for your product. You might be required to return the defective CRU. When return is required: (1) return instructions, a prepaid shipping label, and a container will be included with the replacement CRU; and (2) you might be charged for the replacement CRU if Lenovo does not receive the defective CRU within thirty (30) days of your receipt of the replacement CRU. See your Lenovo Limited Warranty documentation for full details.

ThinkPad computers contain the following types of CRUs:

- **Self-service CRUs:** These CRUs unplug or are held by no more than two screws. Examples of these types of CRUs include the ac power adapter, power cord, battery, and hard disk drive. Other self-service CRUs depending on product design might include the memory module, wireless card, keyboard, and palm rest with finger print reader and touch pad.
- **Optional-service CRUs:** These CRUs are isolated parts within the computer that are concealed by an access panel that is typically secured by more than two screws. Once the access panel is removed, the specific CRU is visible.

Major FRUs and CRUs

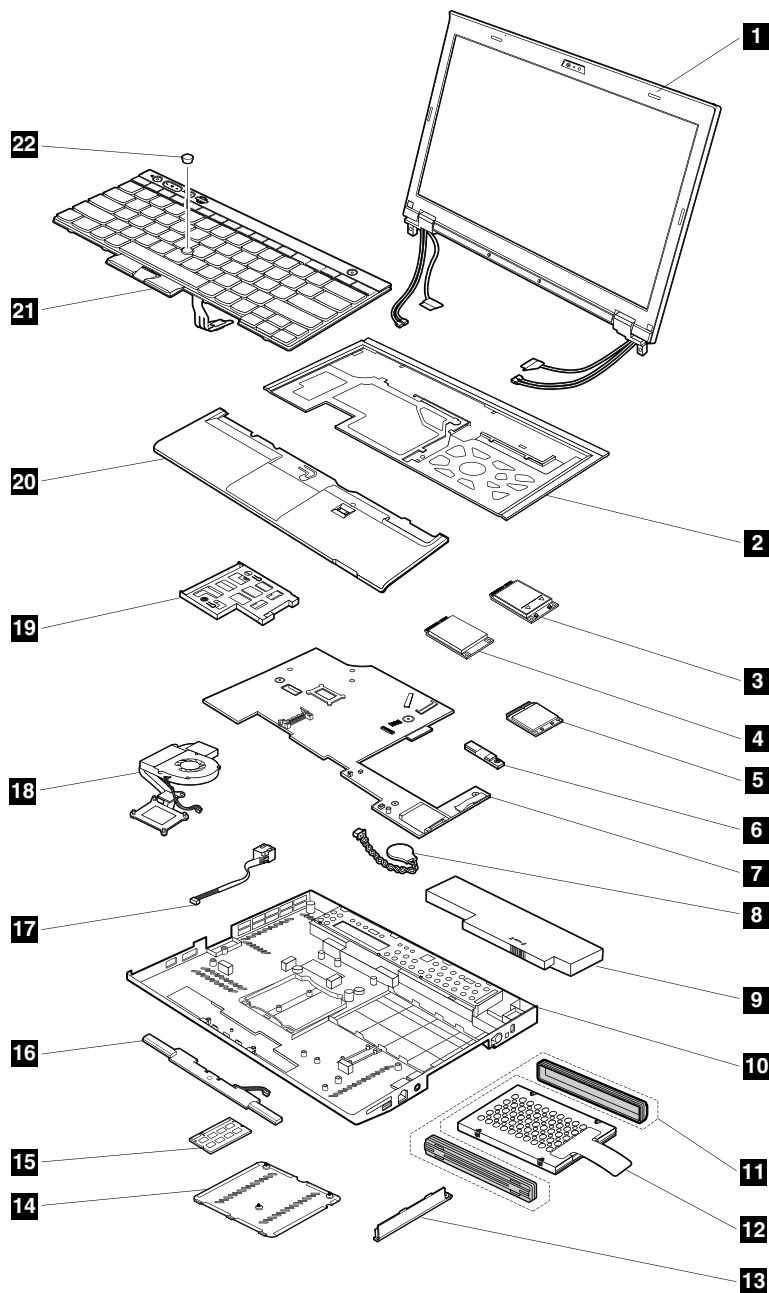

Table 9. Major FRUs and CRUs

No.	FRU description	Self-service CRU	Optional-service CRU
1	LCD unit (see “LCD FRUs and CRUs” on page 48)	No	No
2	Keyboard bezel	No	No
3	PCI Express Mini Card for wireless WAN	No	No
4	mSATA solid-state drive	No	No
5	PCI Express Mini Card for wireless LAN/WiMAX	No	No
6	Bluetooth daughter card	No	No

Table 9. Major FRUs and CRUs (continued)

No.	FRU description	Self-service CRU	Optional-service CRU
7	System board	No	No
8	Backup battery	No	Yes
9	Battery pack	Yes	No
10	Base cover assembly	No	No
11	Hard disk drive rubber rails or solid-state drive spacers	Yes	No
12	Hard disk drive or solid-state drive	Yes	No
13	Hard disk drive cover	Yes	No
14	Memory module slot cover	Yes	No
15	Memory module	Yes	No
16	Speaker assembly	No	Yes
17	DC-in connector	No	No
18	Thermal fan assembly	No	No
19	ExpressCard slot	No	No
20	Palm rest	No	Yes
21	Keyboard	Yes	No
22	TrackPoint cap	Yes	No

LCD FRUs and CRUs

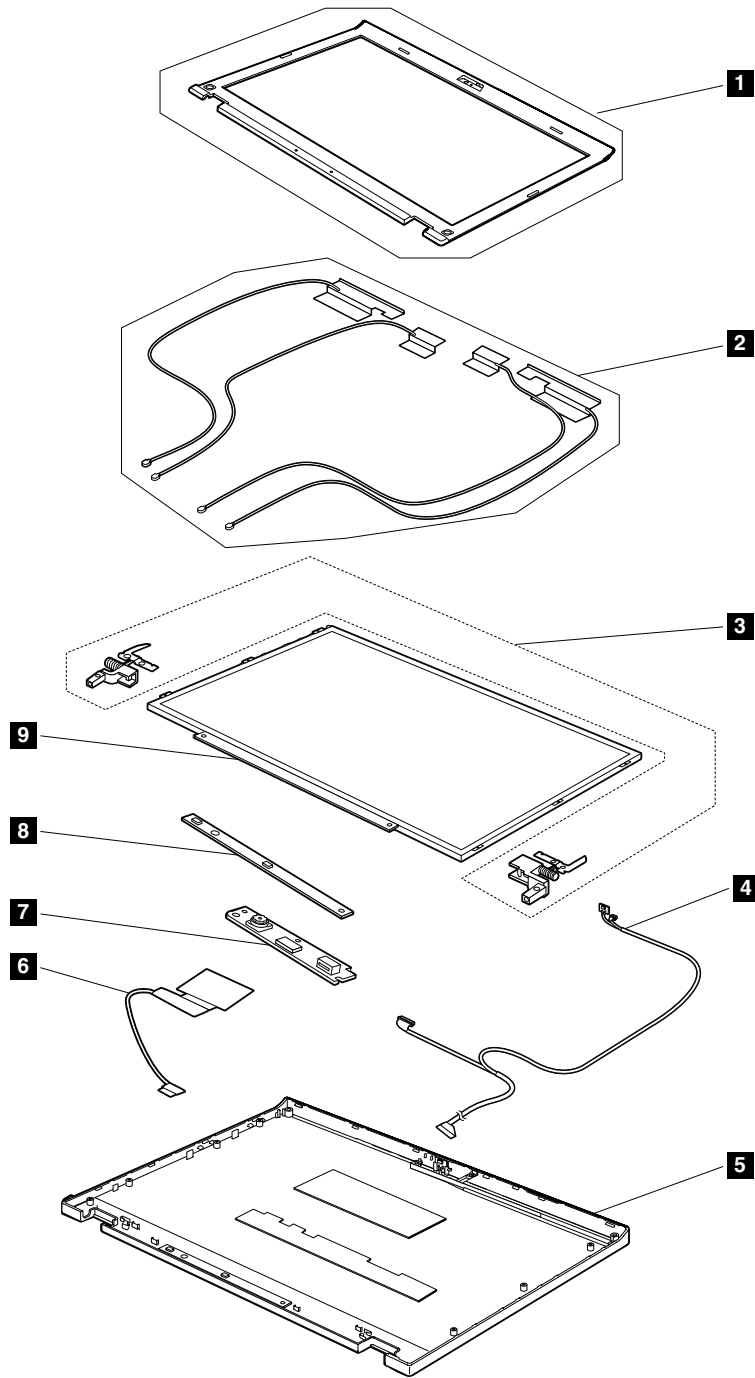

Table 10. LCD FRUs and CRUs

No.	FRU description	Self-service CRU	Optional-service CRU
1	LCD front bezel	No	No
2	Wireless antenna set	No	No
3	Hinges	No	No
4	LED and camera cable	No	No
5	LCD rear cover assembly	No	No

Table 10. LCD FRUs and CRUs (continued)

No.	FRU description	Self-service CRU	Optional-service CRU
6	LCD cable	No	No
7	Integrated camera	No	No
8	LED board	No	No
9	LCD panel	No	No

Looking up FRU information

For detailed FRU information, including part numbers, descriptions, and substitution part numbers, go to <http://www.lenovo.com/serviceparts-lookup>.

Chapter 8. FRU replacement notices

CRU statement for customers:

You can resolve some problems with your product with a replacement part you can install yourself, called a “Customer Replaceable Unit” or “CRU.” Some CRUs are designated as self-service CRUs and others are designated as optional-service CRUs. *Installation of self-service CRUs is your responsibility. For optional-service CRUs, you can either install the CRU yourself or you can request that a Service Provider install the CRU according to the warranty service for your product.* If you intend on installing the CRU, Lenovo will ship the CRU to you. CRU information and replacement instructions are shipped with your product and are available from Lenovo at any time upon request. You can find a list of CRUs for your product in this *Hardware Maintenance Manual*. An electronic version of this manual can be found at <http://www.lenovo.com/support>. Click **User Guides & Manuals** and then follow the on-screen instructions to find the manual for your product. You might be required to return the defective CRU. When return is required: (1) return instructions, a prepaid shipping label, and a container will be included with the replacement CRU; and (2) you might be charged for the replacement CRU if Lenovo does not receive the defective CRU within thirty (30) days of your receipt of the replacement CRU. See your Lenovo Limited Warranty documentation for full details.

Screw notices

Loose screws can cause a reliability problem. In the ThinkPad notebook computer, this problem is addressed with special nylon-coated screws that have the following characteristics:

- They maintain tight connections.
- They do not easily come loose, even with shock or vibration.
- They are harder to tighten.

Do the following when you service this machine:

- Keep the screw kit in your tool bag. For the part number of the screw kit, go to <http://www.lenovo.com/serviceparts-lookup>.
- It is recommended to use new screws.
- It is recommended to use each screw only once.
- Use a torque screwdriver if you have one.

Tighten screws as follows:

- **Plastic to plastic**

Turn an additional 90 degrees after the screw head touches the surface of the plastic part:

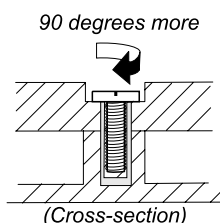

- **Logic card to plastic**

Turn an additional 180 degrees after the screw head touches the surface of the logic card:

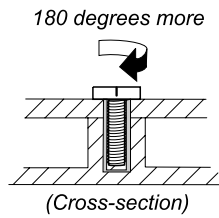

Notes:

- Ensure that you use the correct screw. It is recommended to use new screws for replacements. If you have a torque screwdriver, tighten all screws firmly to the torque specified in the screw information table for each step.
- Ensure torque screwdrivers are calibrated correctly following country specifications.

Retaining serial numbers

This section includes the following descriptions:

- “Restoring the serial number of the system unit” on page 52
- “Retaining the UUID” on page 53
- “Reading or writing the ECA information” on page 53

Restoring the serial number of the system unit

When the computer was manufactured, the EEPROM on the system board was loaded with the serial numbers of the system and all major components. These numbers need to remain the same throughout the life of the computer.

If you replace the system board, you must restore the serial number of the system unit to its original value.

Before replacing the system board, save the original serial number by doing the following:

1. Install the LENOVO ThinkPad Hardware Maintenance Diskette Version 1.76 or later, and restart the computer.
2. From the main menu, select **1. Set System Identification**.
3. Select **2. Read S/N data from EEPROM**. The serial number of the system unit is listed as: **20: Serial number**.
4. Write down that number.

Note: The serial number of the system unit also is written on the label attached to the bottom of the computer.

After you have replaced the system board, restore the serial number by doing the following:

1. Install the LENOVO ThinkPad Hardware Maintenance Diskette Version 1.76 or later and restart the computer.
2. From the main menu, select **1. Set System Identification**.
3. Select **1. Add S/N data from EEPROM**. Follow the instructions on the screen.

If the MTM and Product ID numbers differ from each other on the rear label, use what is shown for the Product ID field. See the following example:

MTM on the rear label:

TTTT-CTO S/N SSSSSSS

Product ID on the rear label:

TTTT-MMM (Use this number when setting Serial Number.)

In the example, the Serial Number to be input is “1STTTTMMMSSSSSSSS”.

Retaining the UUID

The Universally Unique Identifier (UUID) is a 128-bit number uniquely assigned to your computer at production and stored in the EEPROM of your system board.

The algorithm that generates the number is designed to provide unique IDs until the year A.D. 3400. No two computers in the world have the same number.

When you replace the system board, you must set the UUID on the new system board as follows:

1. Install the LENOVO ThinkPad Hardware Maintenance Diskette Version 1.76 or later, and restart the computer.
2. From the main menu, select **4. Assign UUID**. A new UUID is created and written. If a valid UUID already exists, it is not overwritten.

Reading or writing the ECA information

Information on Engineering Change Announcements (ECA) are stored in the EEPROM of the system board. The electronic storage of this information simplifies the procedure to check if the ECA has been previously applied to a machine. The machine does not need to be disassembled to check for the ECA application.

To check what ECAs have been previously applied to the machine, use the ECA Information Read/Write function on the LENOVO ThinkPad Hardware Maintenance Diskette Version 1.76 or later.

1. Insert the LENOVO ThinkPad Hardware Maintenance Diskette Version 1.76 or later, and restart the computer.
2. From the main menu, select **6. Set ECA Information**.
3. To read the ECA information, select **2. Read ECA/rework number from EEPROM** and follow the instructions on the screen.
4. To read the box build date, select **5. Read box build date from EEPROM**, and follow the instructions on the screen.

After an ECA has been applied to the machine, the EEPROM must be updated to reflect the ECA's application. Use the LENOVO ThinkPad Hardware Maintenance Diskette Version 1.76 or later to update the EEPROM.

Note: Only the ECA number is stored in the EEPROM. The machine type of the ECA is assumed to be the same as the machine type of the machine that had the ECA applied to it.

1. Insert the LENOVO ThinkPad Hardware Maintenance Diskette Version 1.76 or later, and restart the computer.
2. From the main menu, select **6. Set ECA Information**.
3. To write the ECA information, select **1. Write ECA/rework number from EEPROM**, and follow the instructions on the screen.
4. To write the box build date, select **4. Write box build date from EEPROM**, and follow the instructions on the screen.

If the system board is being replaced, try to read the ECA information from the old system board and transfer the information to the new system. If the system board is inoperable, this will not be possible.

Chapter 9. Removing or replacing a FRU

This chapter provides instructions on how to remove or replace a FRU.

CRU statement for customers:

You can resolve some problems with your product with a replacement part you can install yourself, called a “Customer Replaceable Unit” or “CRU.” Some CRUs are designated as self-service CRUs and others are designated as optional-service CRUs. *Installation of self-service CRUs is your responsibility. For optional-service CRUs, you can either install the CRU yourself or you can request that a Service Provider install the CRU according to the warranty service for your product.* If you intend on installing the CRU, Lenovo will ship the CRU to you. CRU information and replacement instructions are shipped with your product and are available from Lenovo at any time upon request. You can find a list of CRUs for your product in this *Hardware Maintenance Manual*. An electronic version of this manual can be found at <http://www.lenovo.com/support>. Click **User Guides & Manuals** and then follow the on-screen instructions to find the manual for your product. You might be required to return the defective CRU. When return is required: (1) return instructions, a prepaid shipping label, and a container will be included with the replacement CRU; and (2) you might be charged for the replacement CRU if Lenovo does not receive the defective CRU within thirty (30) days of your receipt of the replacement CRU. See your Lenovo Limited Warranty documentation for full details.

General guidelines

When removing or replacing a FRU, be sure to observe the following general guidelines:

1. Do not try to service any computer unless you have been trained and certified. An untrained person runs the risk of damaging parts.
2. Before replacing any FRU, review Chapter 8 “FRU replacement notices” on page 51.
3. Begin by removing any FRUs that have to be removed before replacing the failing FRU. Any such FRUs are listed at the beginning of each FRU replacement procedure. Remove them in the order in which they are listed.
4. Follow the correct sequence in the steps for removing a FRU, as given in the drawings by the numbers in square callouts.
5. When turning a screw, turn it in the direction as given by the arrow in the drawing.
6. When removing a FRU, move it in the direction as given by the arrow in the drawing.
7. To put the new FRU in place, reverse the removal procedure and follow any notes that pertain to replacement.
8. When replacing a FRU, use the correct screw(s) as shown in the replacement procedure.



Before removing any FRU, turn off the computer, unplug all power cords from electrical outlets, remove the battery pack, and then disconnect any interconnecting cables.

Attention: After replacing a FRU, do not turn on the computer until you have made sure that all screws, springs, and other small parts are in place and none are loose inside the computer. Verify this by shaking the computer gently and listening for rattling sounds. Metallic parts or metal flakes can cause electrical short circuits.

Attention: The system board is sensitive to, and can be damaged by, electrostatic discharge. Before touching it, establish personal grounding by touching a ground point with one hand or by using an electrostatic discharge (ESD) strap.

Before servicing the computer

Removing the SIM card

Depending on the model, the computer you are servicing might have a SIM card slot. If the customer has installed a SIM card in the slot, remove it before servicing.

To remove the SIM card, you need to remove the battery pack first. See “1010 Battery pack” on page 56.

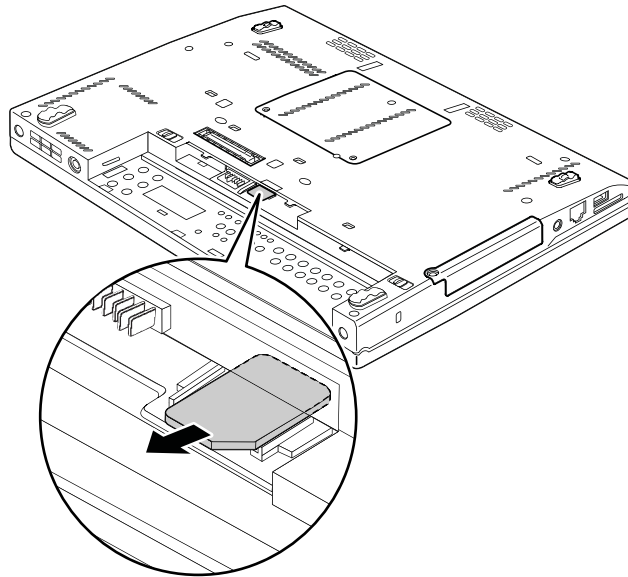

After you finish the servicing, ensure that you insert the card back into the slot firmly.

1010 Battery pack

Important notice for replacing a battery pack:

- The Lenovo Solution Center program provides an automatic battery diagnostic test that determines if the battery pack is defective. A battery pack FRU should not be replaced unless this diagnostic test shows that the battery is defective. The only exception to this is if the battery pack is physically damaged or a customer is reporting a possible safety issue.
- If the Lenovo Solution Center program is not installed in the computer, the customer should download this program before a non-physically damaged battery pack is replaced. Note that the replacement of a physically damaged battery pack is not covered by the warranty.

Removal steps of battery pack



Use only the authorized battery specified for your computer. Any other battery could ignite or explode.

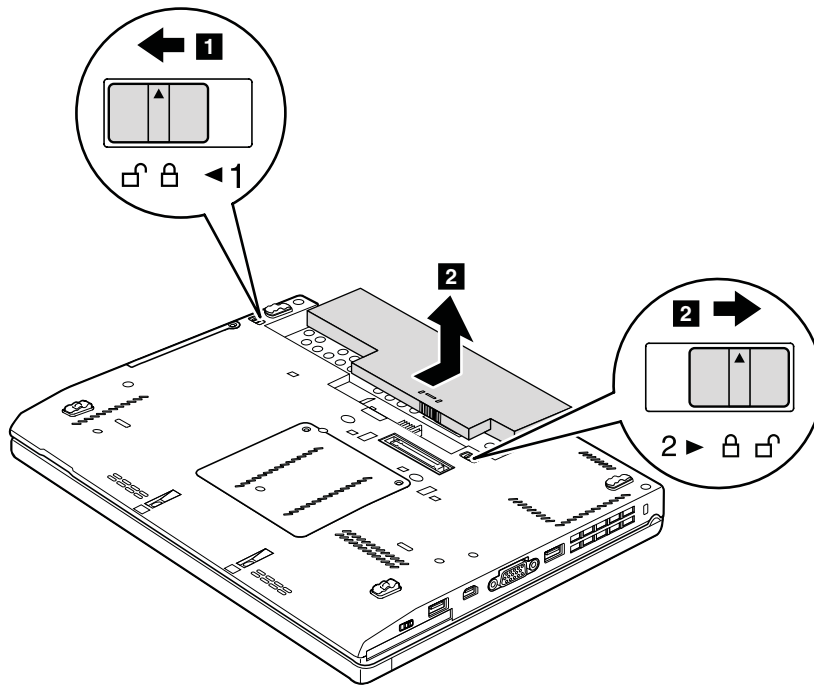

When installing: Install the battery pack in the slot, and then ensure that the battery lock is in the locked position.

1020 Hard disk drive or solid-state drive

For access, remove this FRU:

- “1010 Battery pack” on page 56

Attention:

- Do not drop the drive or apply any physical shock to it. The drive is sensitive to physical shock. Improper handling can cause damage and permanent loss of data.
- Before removing the drive, have the user make a backup copy of all the information on it if possible.
- Never remove the drive while the computer is operating or in suspend mode.

Removal steps of hard disk drive or solid-state drive

Loosen the screw **1**.

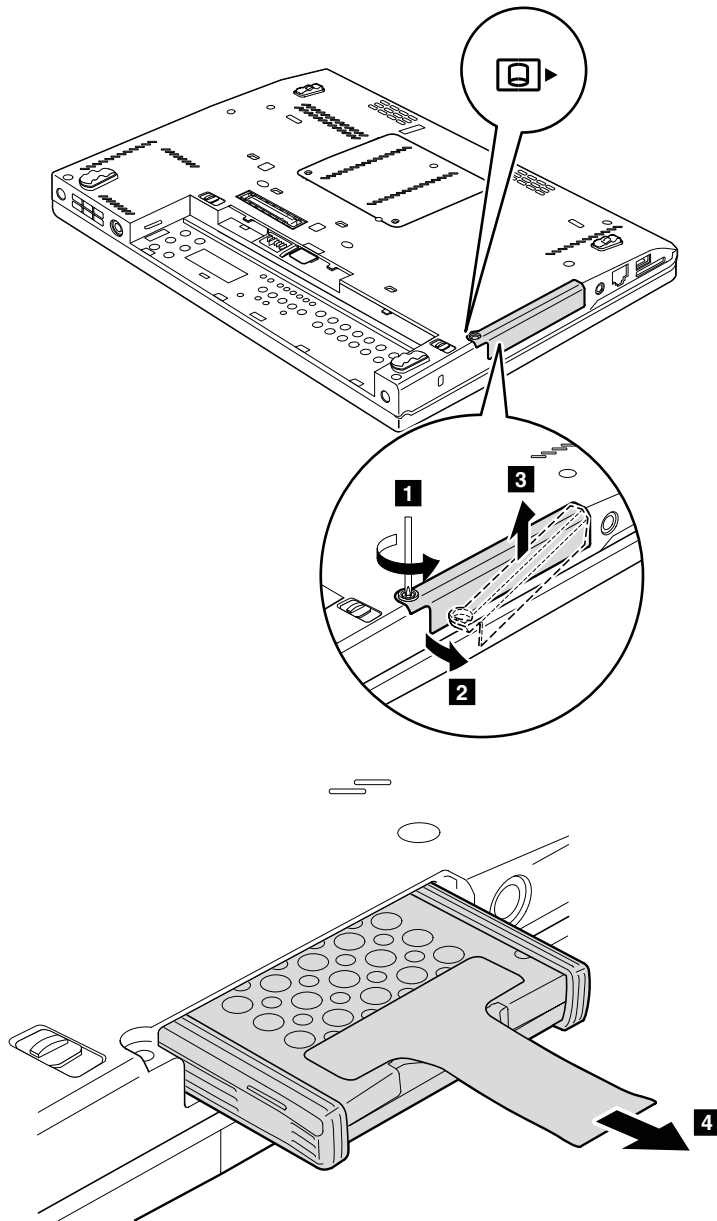

For hard disk drive and rubber rails:

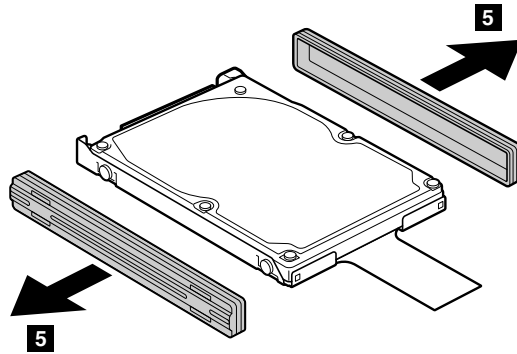

For solid-state drive and spacers:

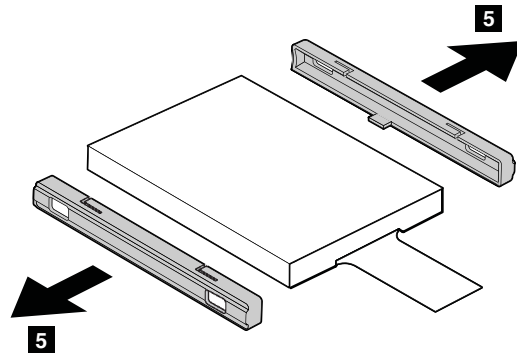

When installing: Ensure that the solid-state drive spacers or the hard disk drive rubber rails are attached firmly.

1030 Memory module

For access, remove this FRU:

- “1010 Battery pack” on page 56

Removal steps of memory module

Remove the memory module slot cover as shown in the following illustration.

Loosen the screws **1**.

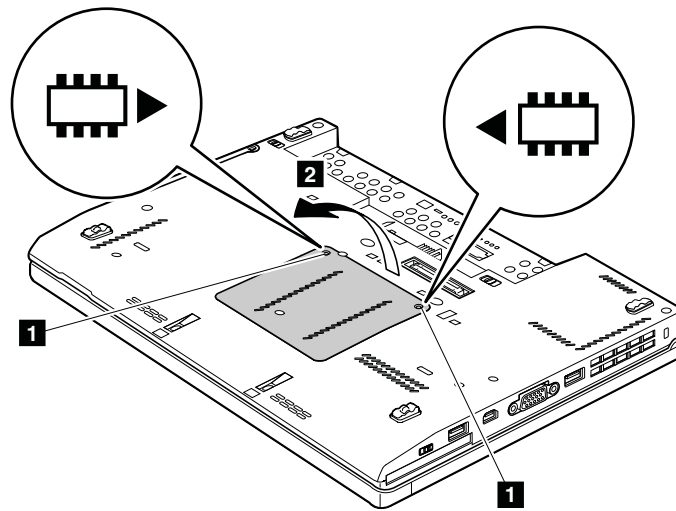

If only one memory module is to be installed on the computer you are servicing, it must be installed in SLOT-0 **a**, but not in SLOT-1 **b**.

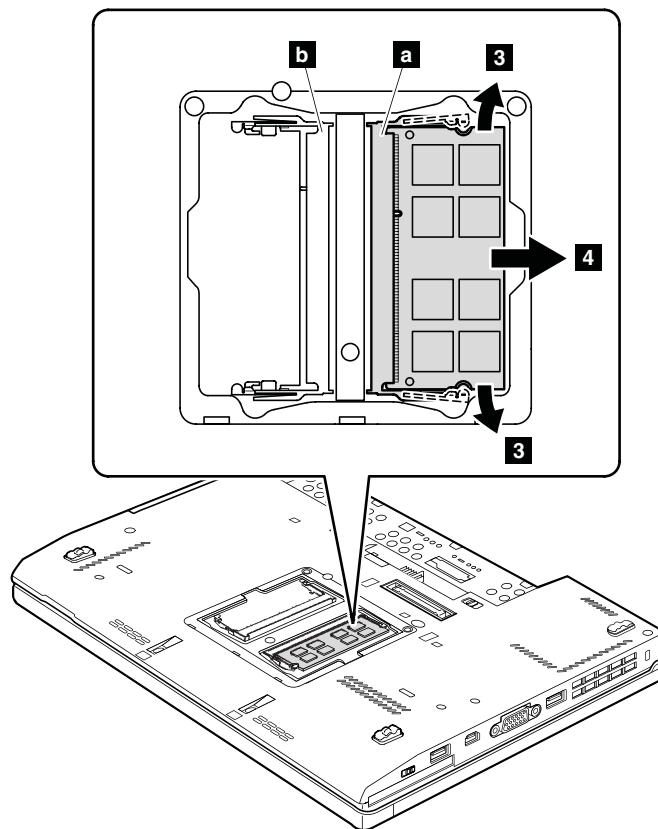

When installing: Insert the notched end of the memory module into the slot. Press the memory module firmly, and pivot it until it snaps into place. Ensure that it is firmly installed in the slot and does not move easily.

1040 Keyboard

For access, remove this FRU:

- “1010 Battery pack” on page 56

Removal steps of keyboard

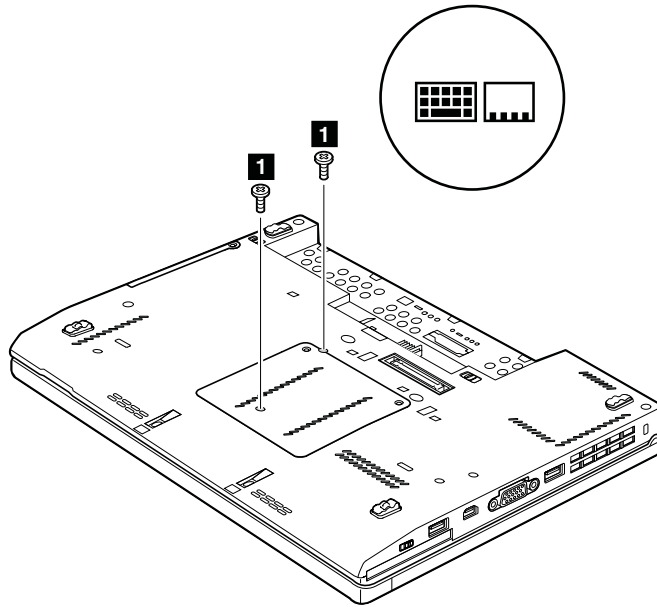

Step	Screw (quantity)	Color	Torque
1	M2 × 5 mm, wafer-head, nylon-coated (2)	Black	0.181 Nm (1.85 kgf-cm)

Press the keyboard in the direction shown by the arrows **2** until the rear edge of the keyboard is detached from the keyboard bezel.

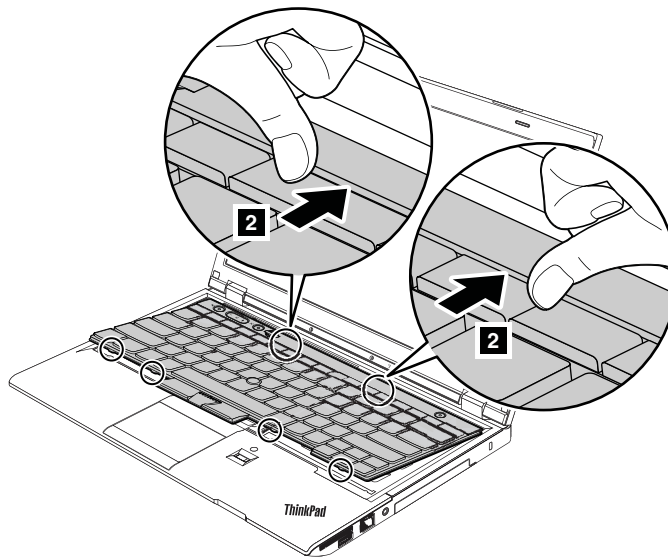

Lift the keyboard a little in the direction shown by the arrow **3**, and then detach the connector **4**.

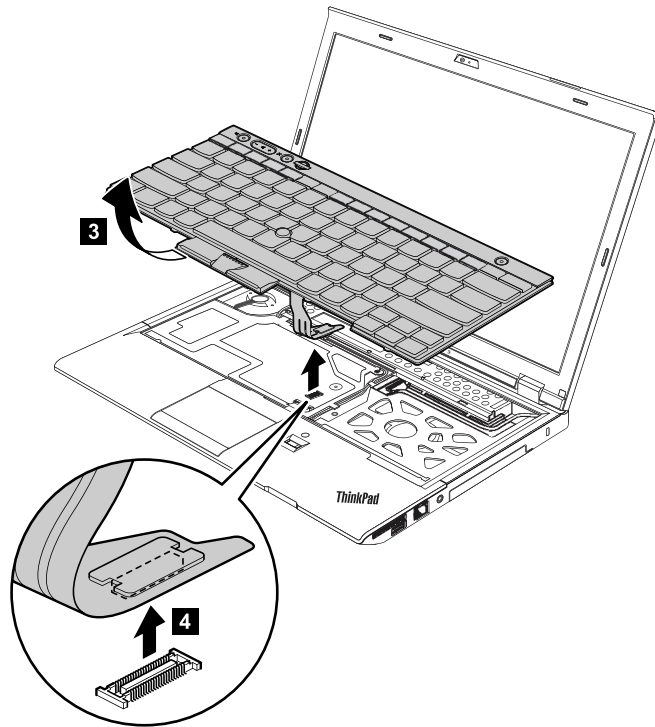

When installing:

1. Attach the keyboard connector firmly.
2. Attach the keyboard and ensure that the hooks **a** on the front edge of the keyboard are under the frame.

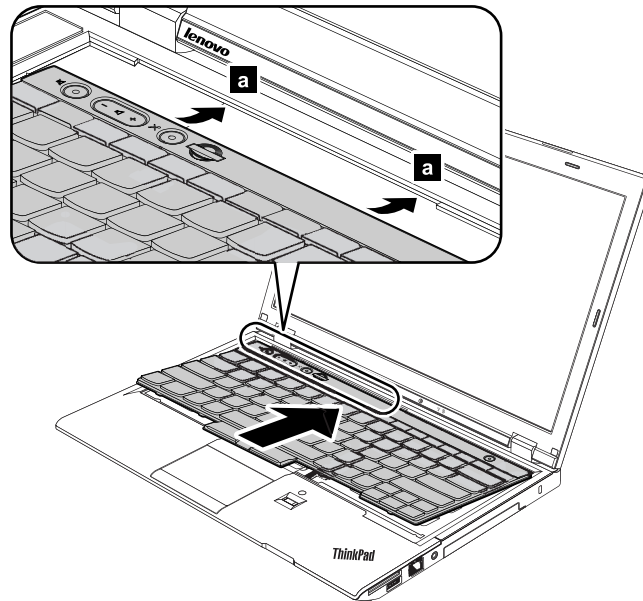

- When the front edge of the keyboard is housed firmly, gently press the keys with your palms and slightly slide the keyboard toward you until the keyboard is in place.

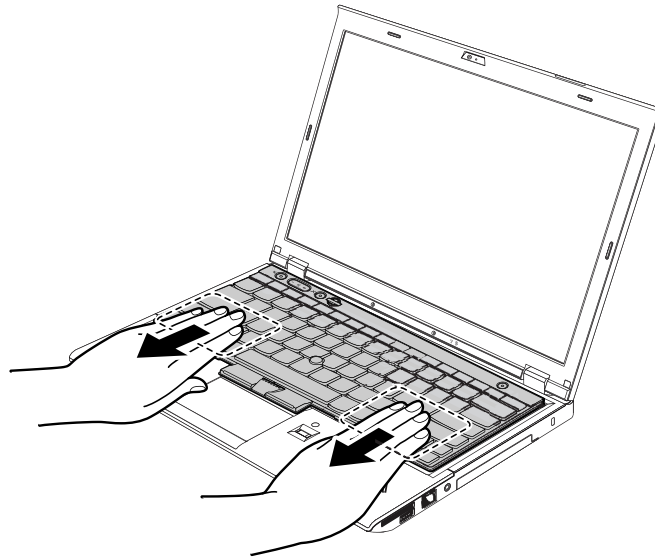

- Secure the keyboard by tightening the screws from the bottom side of the computer.

1050 Palm rest

For access, remove these FRUs in order:

- “1010 Battery pack” on page 56
- “1040 Keyboard” on page 60

Removal steps of palm rest

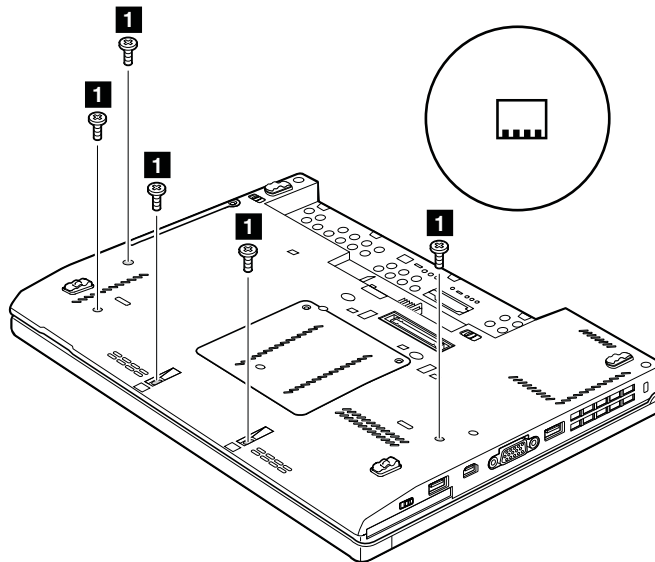

Step	Screw (quantity)	Color	Torque
1	M2 × 5 mm, wafer-head, nylon-coated (5)	Black	0.181 Nm (1.85 kgf-cm)

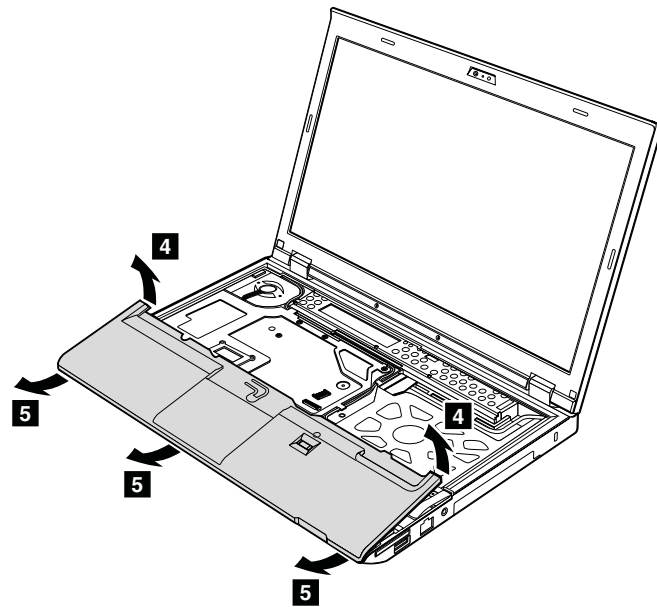
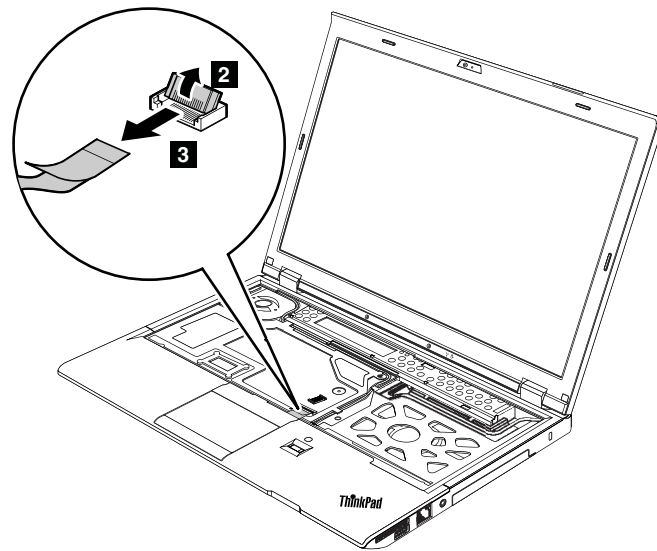

When installing:

1. Attach the connector firmly to the system board.

2. Press the top left and right areas of the palm rest into position **1**. Then, push the front side of the palm rest until it is secured **2**.

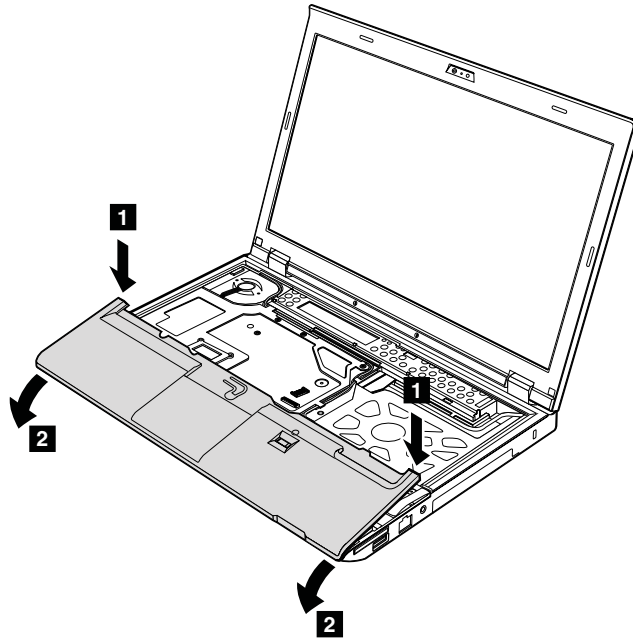

3. Close the LCD cover and turn the computer over. Then fasten five screws to secure the palm rest.

1060 Backup battery



Use only the authorized battery specified for your computer. Any other battery could ignite or explode.

For access, remove these FRUs in order:

- “1010 Battery pack” on page 56
- “1040 Keyboard” on page 60
- “1050 Palm rest” on page 63

Removal steps of backup battery

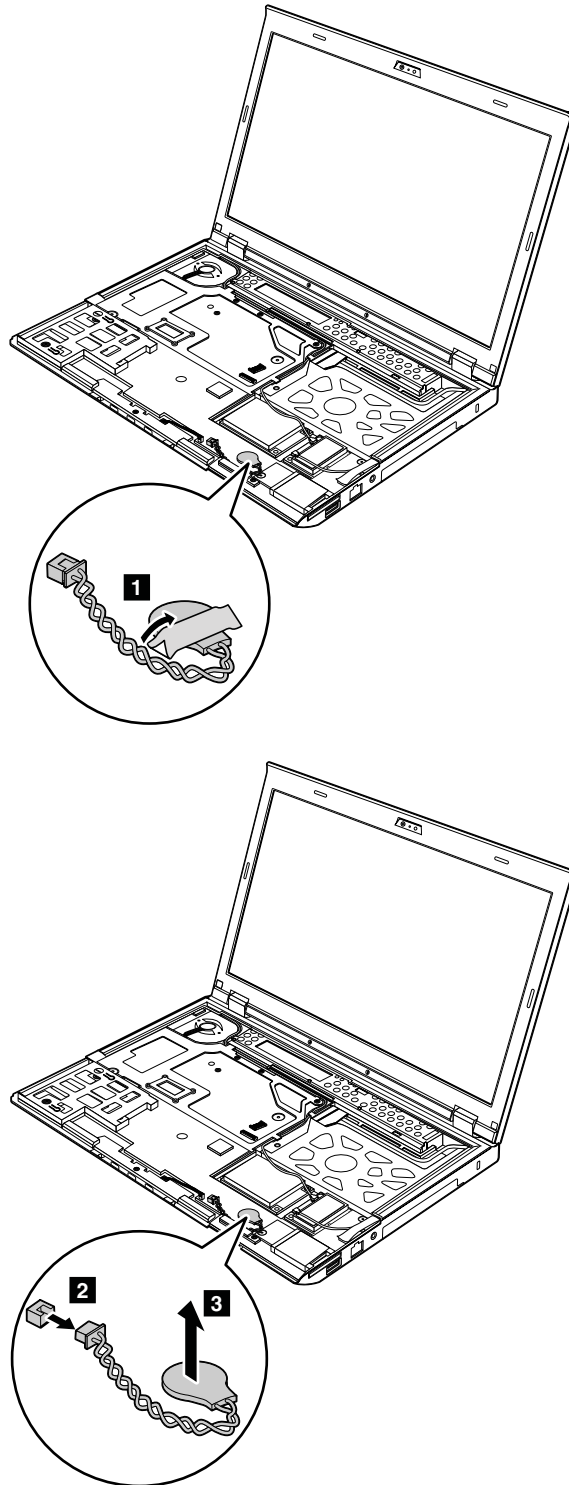

When installing: Ensure that the battery connector is attached firmly.

1070 Speaker assembly

For access, remove these FRUs in order:

- “1010 Battery pack” on page 56
- “1040 Keyboard” on page 60
- “1050 Palm rest” on page 63

Removal steps of speaker assembly

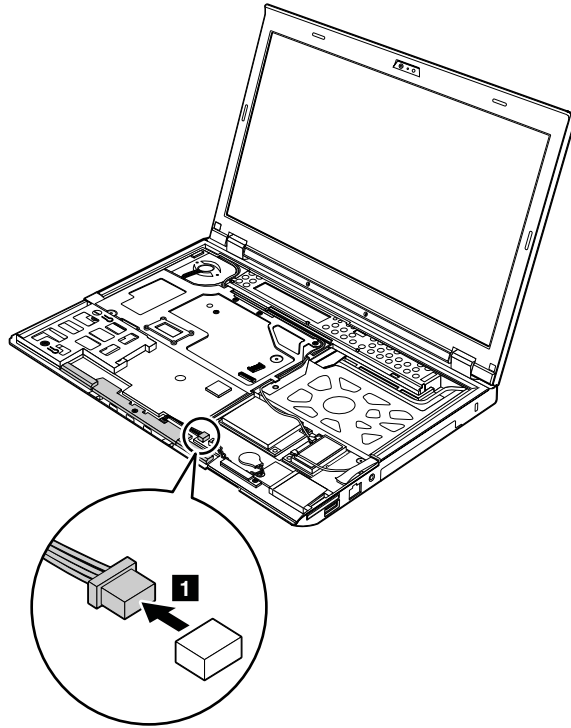

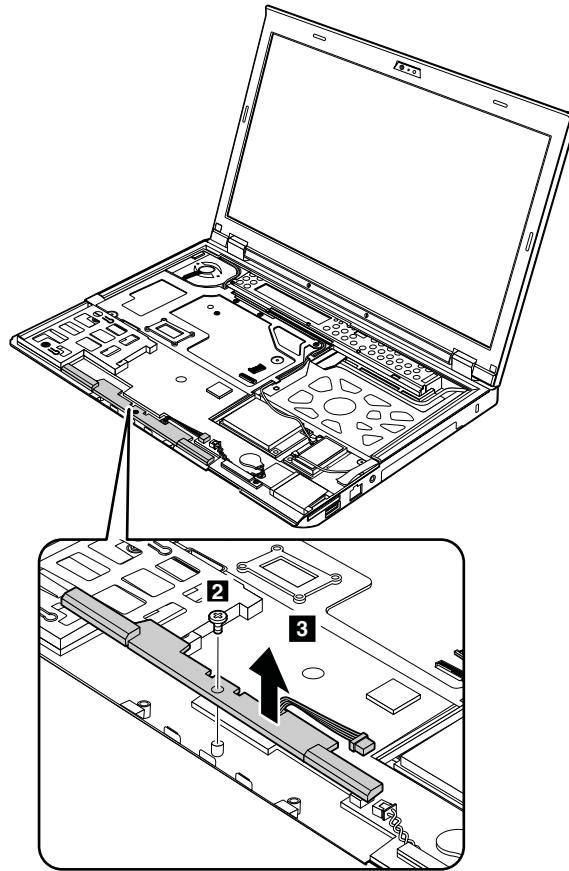

Step	Screw (quantity)	Color	Torque
2	M2 × 3.5 mm, wafer-head, nylon-coated (1)	Silver	0.181 Nm (1.85 kgf-cm)

When installing: Ensure that the speaker connector is attached firmly. Then route the cables and secure them properly as shown in the following illustration.

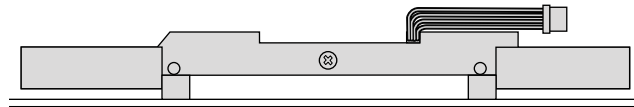

1080 PCI Express Mini Card for wireless LAN/WiMAX

For access, remove these FRUs in order:

- “1010 Battery pack” on page 56
- “1040 Keyboard” on page 60
- “1050 Palm rest” on page 63

Removal steps of PCI Express Mini Card for wireless LAN/WiMAX

Unplug the connectors by using the antenna RF connector removal tool, or pick the connectors with your fingers and gently unplug them in the direction shown by the arrows **1**.

Note: Some models might have three antenna cables.

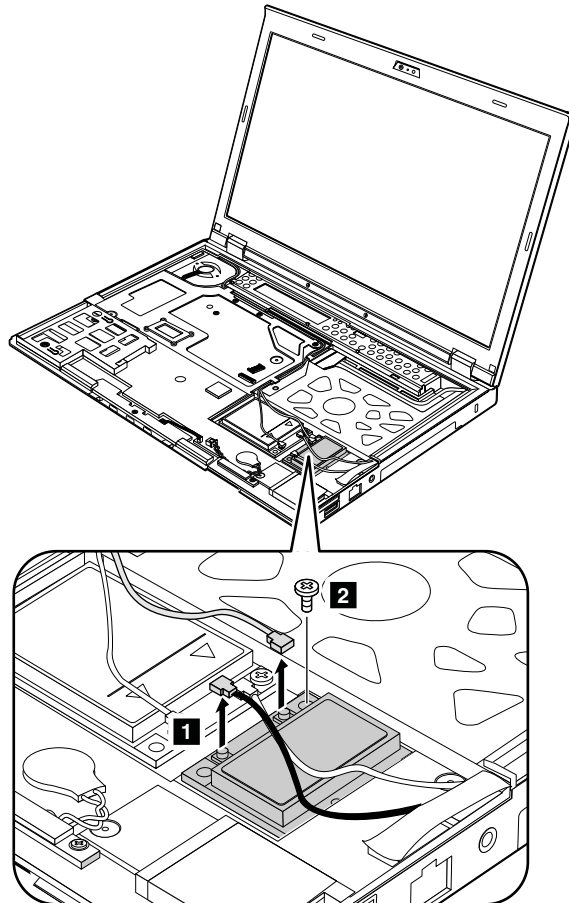

Step	Screw (quantity)	Color	Torque
2	M2 × 3.5 mm, wafer-head, nylon-coated (1)	Silver	0.181 Nm (1.85 kgf-cm)

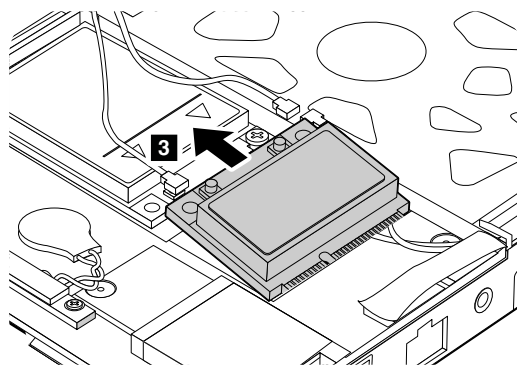

When installing:

- For models with a wireless LAN card that has two antenna connectors, plug the gray cable into the main connector, and the black cable into the auxiliary connector. If the computer you are servicing has three cables, put the white cable in the cable protection tube and secure it with tape.
- For models with a wireless LAN card that has three antenna connectors, plug the gray cable into the main connector, the black cable into the auxiliary connector, and the white cable into the last connector.

1090 PCI Express Mini Card for wireless WAN or mSATA solid-state drive

For access, remove these FRUs in order:

- “1010 Battery pack” on page 56
- “1040 Keyboard” on page 60
- “1050 Palm rest” on page 63

Removal steps of PCI Express Mini Card for wireless WAN (full-size wireless WAN card)

Unplug the connectors by using the antenna RF connector removal tool, or pick the connectors with your fingers and gently unplug them in the direction shown by the arrows **1**.

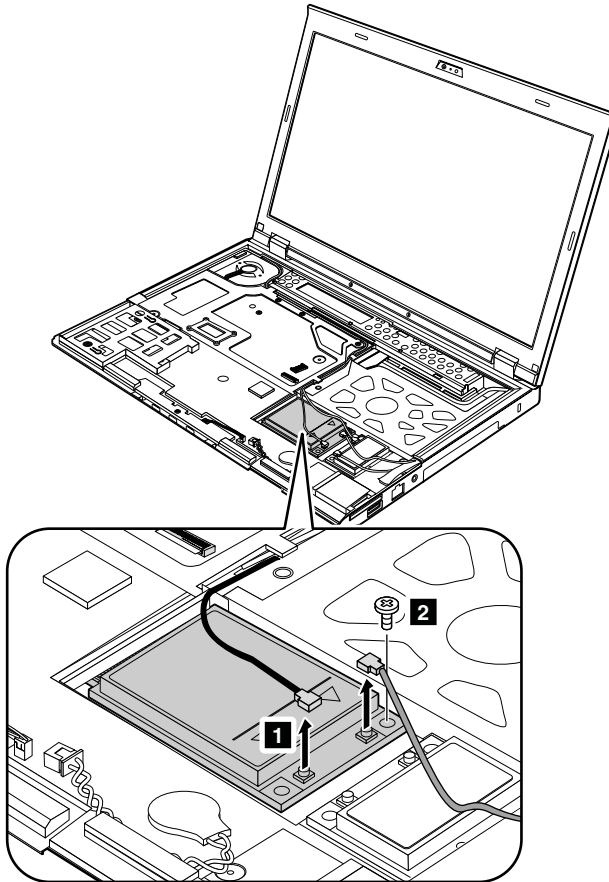

Step	Screw (quantity)	Color	Torque
2	M2 × 3.5 mm, wafer-head, nylon-coated (1)	Silver	0.181 Nm (1.85 kgf-cm)

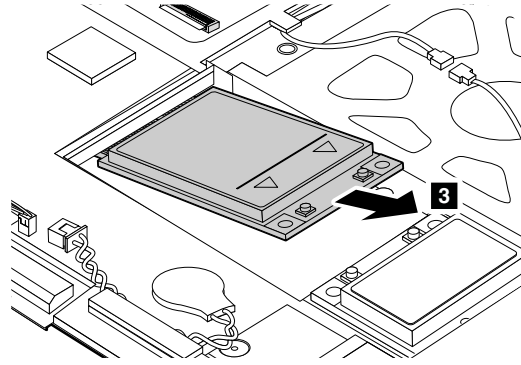

When installing: Plug the red cable into the main connector, and the blue cable into the auxiliary connector on the card.

If the computer you are servicing is a wireless WAN-ready model and does not have a wireless WAN card, route the antenna cables and secure them with tape as shown in the following illustration.

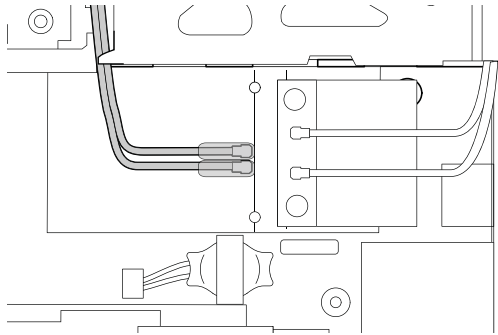

Removal steps of PCI Express Mini Card for wireless WAN (half-size wireless WAN card)

Unplug the connectors by using the antenna RF connector removal tool, or pick the connectors with your fingers and gently unplug them in the direction shown by the arrows **1**.

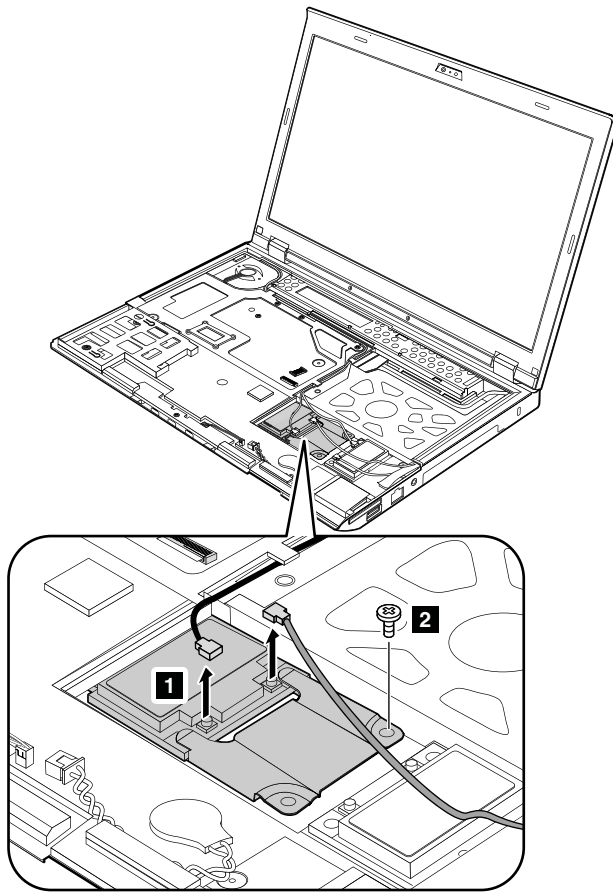

Step	Screw (quantity)	Color	Torque
2	M2 × 3.5 mm, wafer-head, nylon-coated (1)	Silver	0.181 Nm (1.85 kgf-cm)

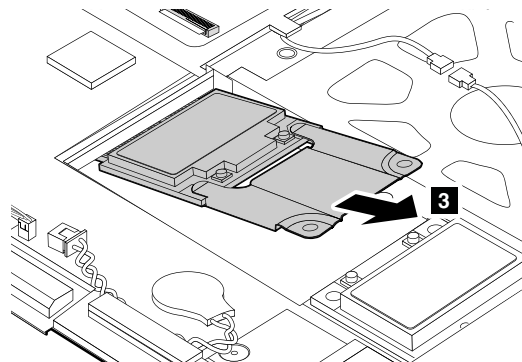

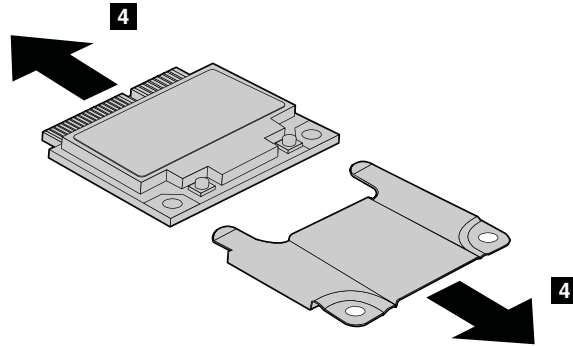

When installing: Plug the red cable into the main connector, and the blue cable into the auxiliary connector on the card.

If the computer you are servicing is a wireless WAN-ready model and does not have a wireless WAN card, route the antenna cables and secure them with tape as shown in the following illustration.

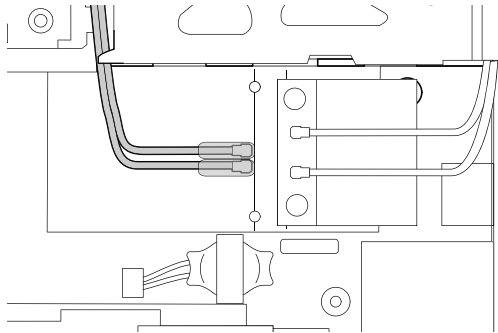

Removal steps of mSATA solid-state drive

The computer comes with either a PCI Express Mini Card for wireless WAN or an mSATA solid-state drive. If the computer is equipped with an mSATA solid-state drive, it is installed in the wireless WAN card slot.

Attention:

- Do not drop the drive or apply any physical shock to it. The drive is sensitive to physical shock. Improper handling can cause damage and permanent loss of data.
- Before removing the drive, have the user make a backup copy of all the information on it if possible.
- Never remove the drive while the computer is operating or in suspend mode.
- Ensure that you partition the mSATA solid-state drive after installing it on the computer you are servicing. Otherwise, the mSATA solid-state drive will not function correctly. For instructions on how to partition an mSATA solid-state drive, go to <http://www.lenovo.com/support/msata-fru>.

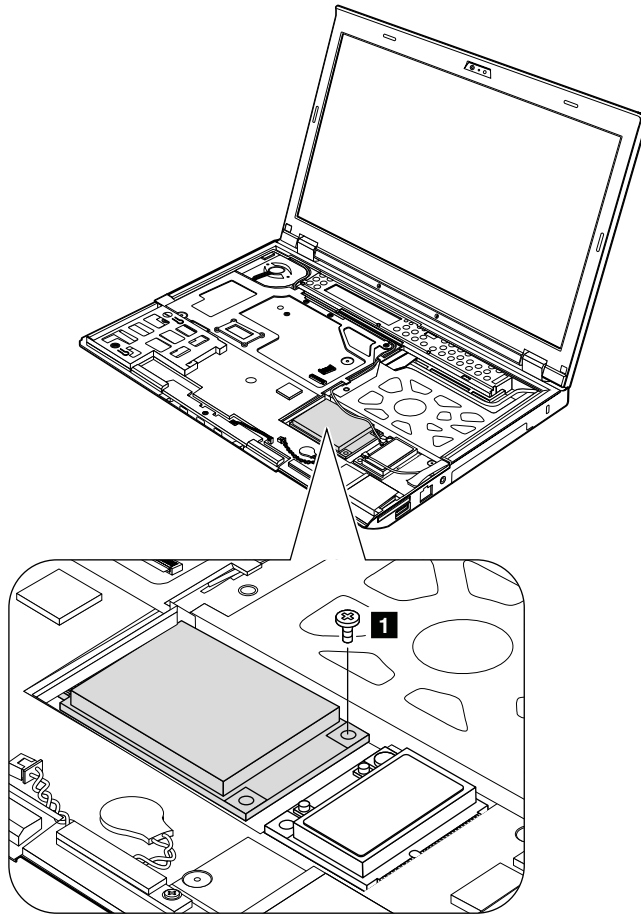

Step	Screw (quantity)	Color	Torque
1	M2 × 3.5 mm, wafer-head, nylon-coated (1)	Silver	0.181 Nm (1.85 kgf-cm)

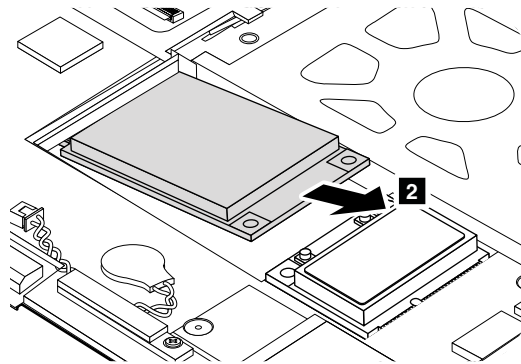

1100 Bluetooth daughter card

For access, remove these FRUs in order:

- “1010 Battery pack” on page 56
- “1040 Keyboard” on page 60
- “1050 Palm rest” on page 63

Removal steps of Bluetooth daughter card

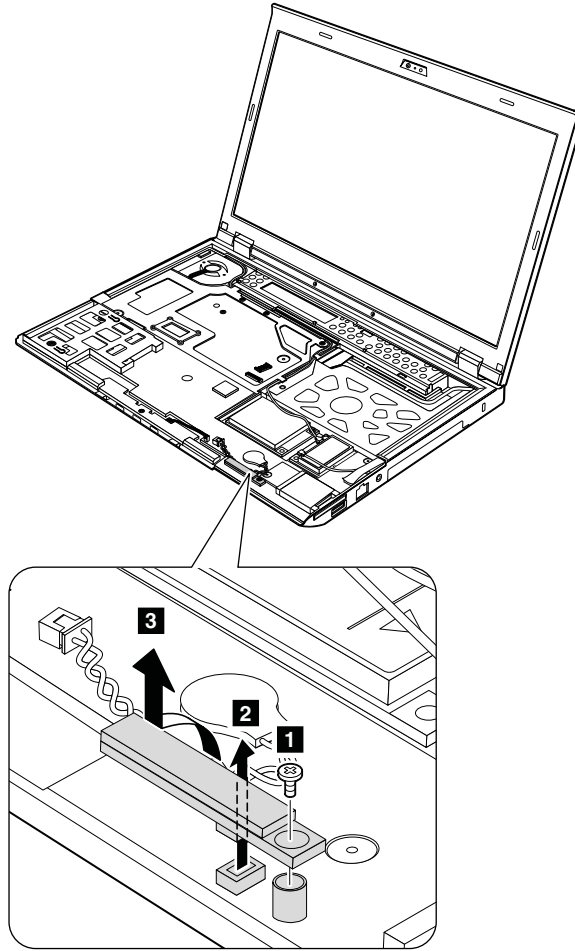

Step	Screw (quantity)	Color	Torque
1	M2 × 3 mm, wafer-head, nylon-coated (1)	Silver	0.181 Nm (1.85 kgf-cm)

When installing: Ensure that the connector is attached firmly.

1110 Keyboard bezel

For access, remove these FRUs in order:

- “1010 Battery pack” on page 56
- “1040 Keyboard” on page 60
- “1050 Palm rest” on page 63

Removal steps of keyboard bezel

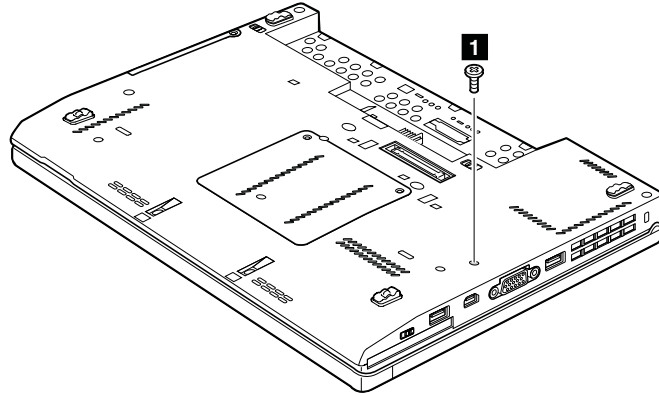

Step	Screw (quantity)	Color	Torque
1	M2 × 5 mm, wafer-head, nylon-coated (1)	Black	0.181 Nm (1.85 kgf-cm)

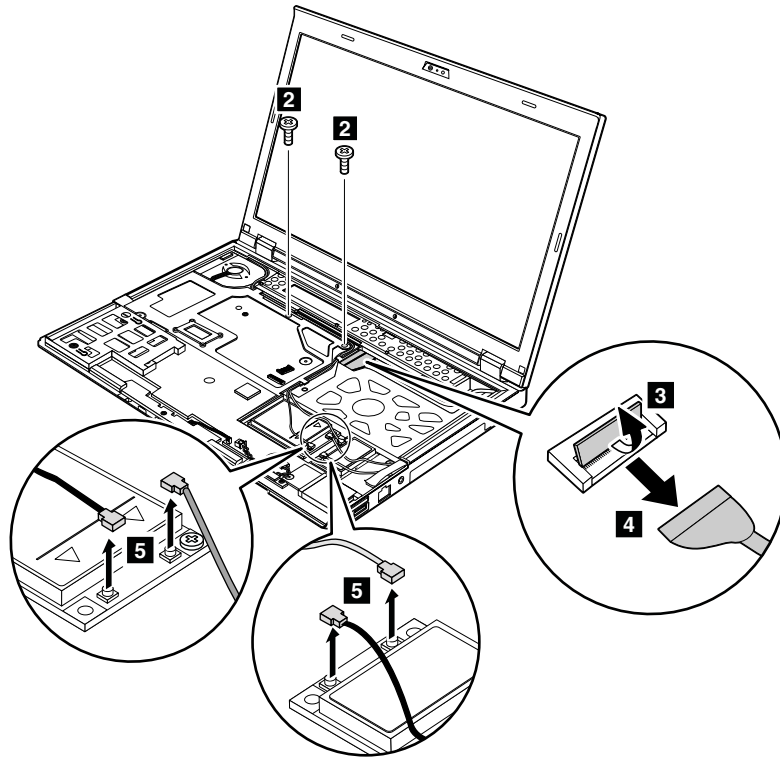

Step	Screw (quantity)	Color	Torque
2	M2 × 3.5 mm, wafer-head, nylon-coated (2)	Silver	0.181 Nm (1.85 kgf-cm)

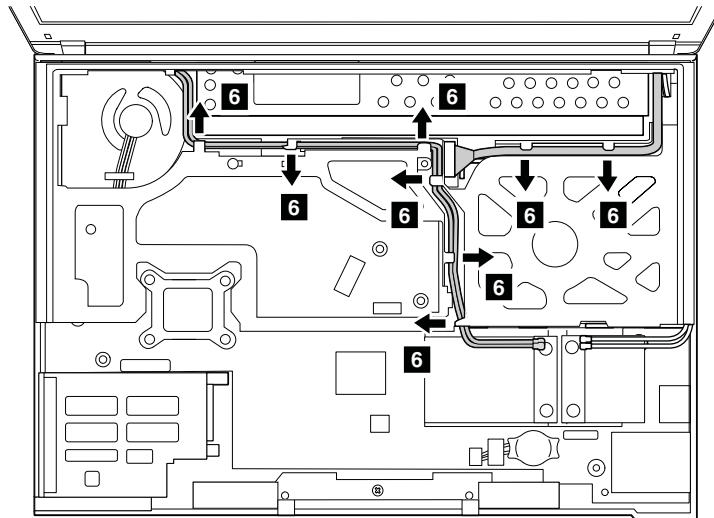

Detach the latches **7**. Then remove the keyboard bezel in the direction shown by the arrows **8**.

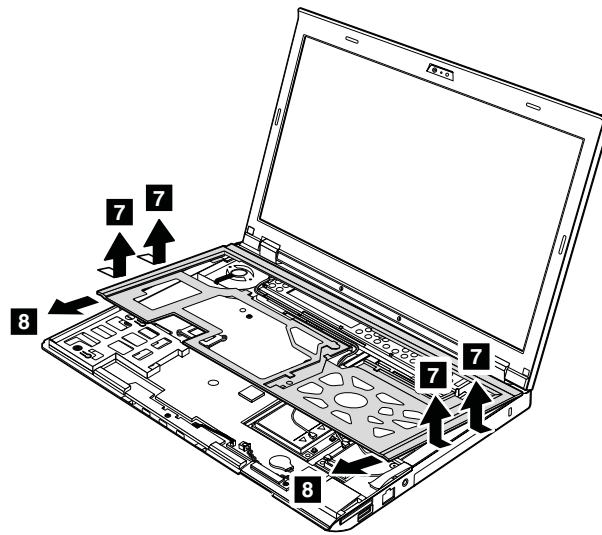

When installing: Ensure that the connector and the latches are attached firmly.

Attention: When you service the keyboard bezel, avoid any kind of rough handling.

1120 LCD unit

For access, remove these FRUs in order:

- “1010 Battery pack” on page 56
- “1040 Keyboard” on page 60
- “1050 Palm rest” on page 63
- “1110 Keyboard bezel” on page 75

Removal steps of LCD unit

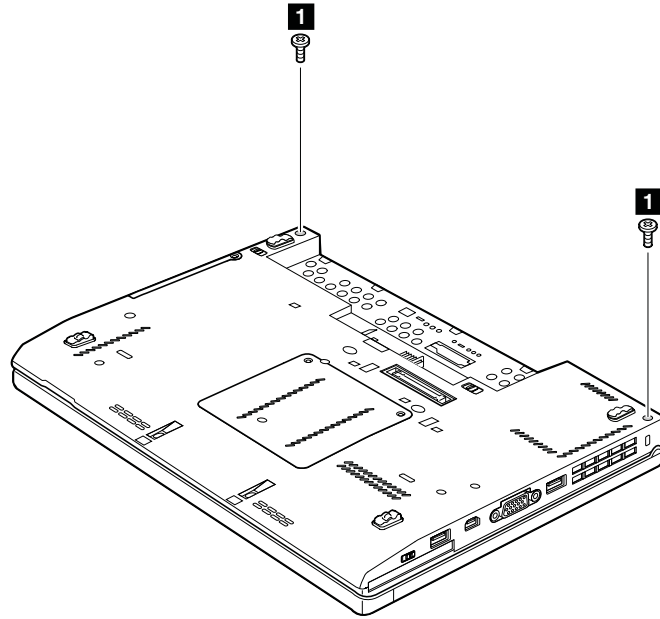

Step	Screw (quantity)	Color	Torque
1	M2 × 5 mm, wafer-head, nylon-coated (2)	Black	0.181 Nm (1.85 kgf-cm)

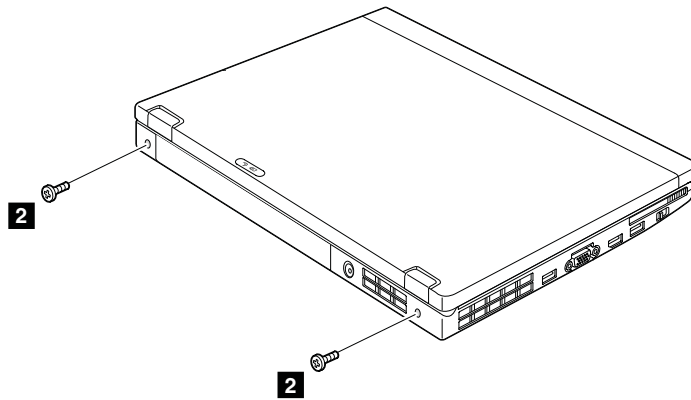

Step	Screw (quantity)	Color	Torque
2	M2 × 5 mm, wafer-head, nylon-coated (2)	Black	0.181 Nm (1.85 kgf-cm)

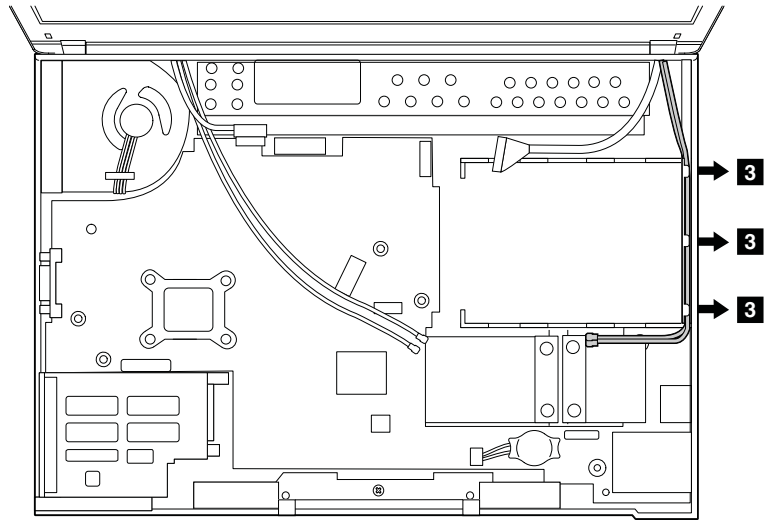

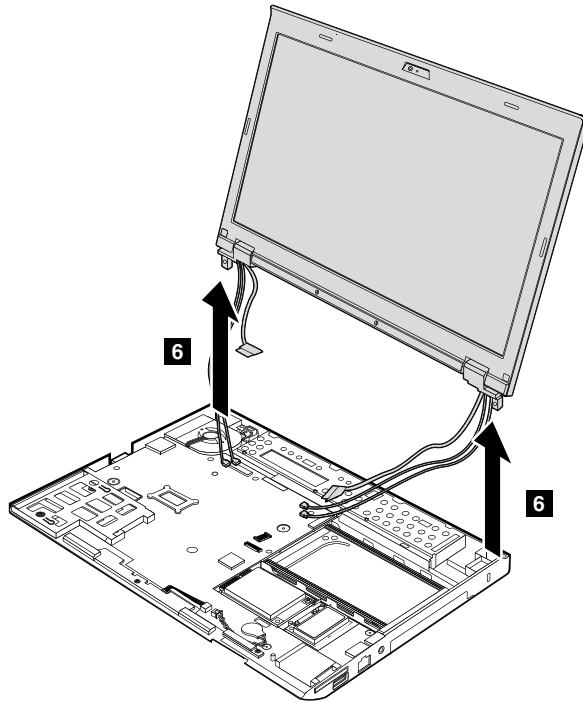

When installing:

- Ensure that you attach the connectors firmly.
- Ensure that you route and tape up the cables correctly in the proper positions as shown in the following illustration.
- When you route the cables, ensure that they are not subject to any tension. Tension could cause the cables to be damaged by the cable guides, or a wire to be broken.

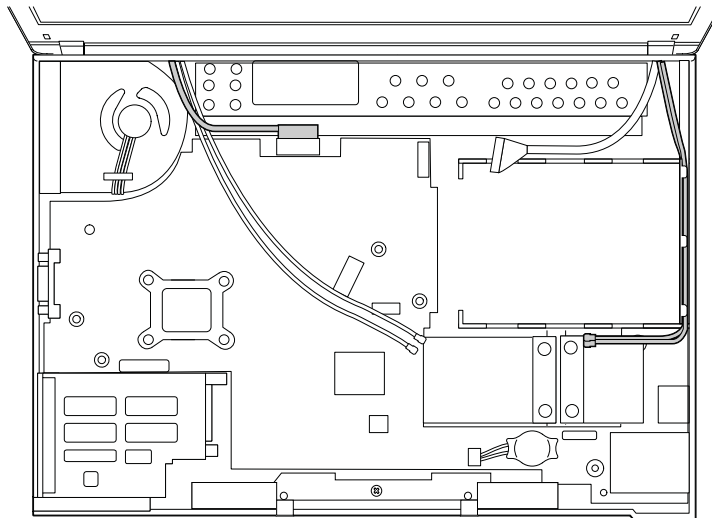

1130 Base cover assembly

For access, remove these FRUs in order:

- “1010 Battery pack” on page 56
- “1020 Hard disk drive or solid-state drive” on page 57
- “1030 Memory module” on page 59

- “1040 Keyboard” on page 60
- “1050 Palm rest” on page 63
- “1060 Backup battery” on page 65
- “1080 PCI Express Mini Card for wireless LAN/WiMAX” on page 68
- “1090 PCI Express Mini Card for wireless WAN or mSATA solid-state drive” on page 70
- “1100 Bluetooth daughter card ” on page 74
- “1110 Keyboard bezel” on page 75
- “1120 LCD unit” on page 77

Removal steps of base cover assembly

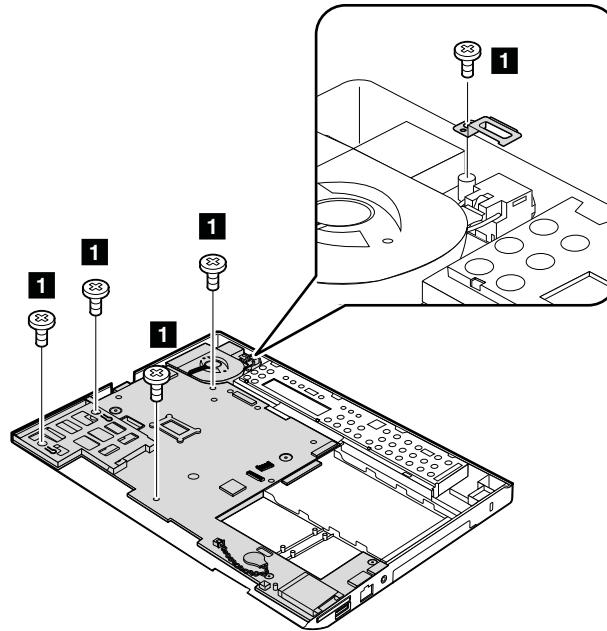

Step	Screw (quantity)	Color	Torque
1	M2 × 3.5 mm, wafer-head, nylon-coated (5)	Silver	0.181 Nm (1.85 kgf-cm)

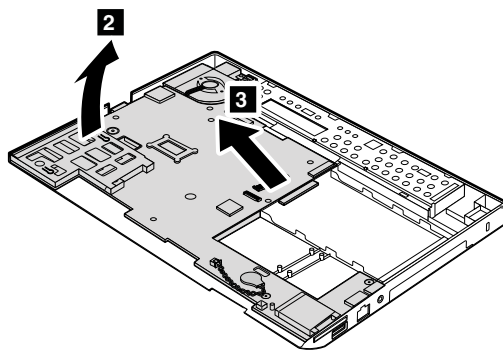

Applying labels to the base cover

The new base cover FRU is shipped with a kit containing labels of several kinds.

Notes:

- If the Certificate of Authentication (COA) label is attached to a part that is replaced, return the old part with the label attached to the customer, or provide a letter to the customer stating what the label was originally on the computer and what the label part number, serial number, and product key were.

- If the base cover has two FCC labels, apply both to the new base cover.

The following labels need to be peeled off from the old base cover, and need to be put on the new base cover.

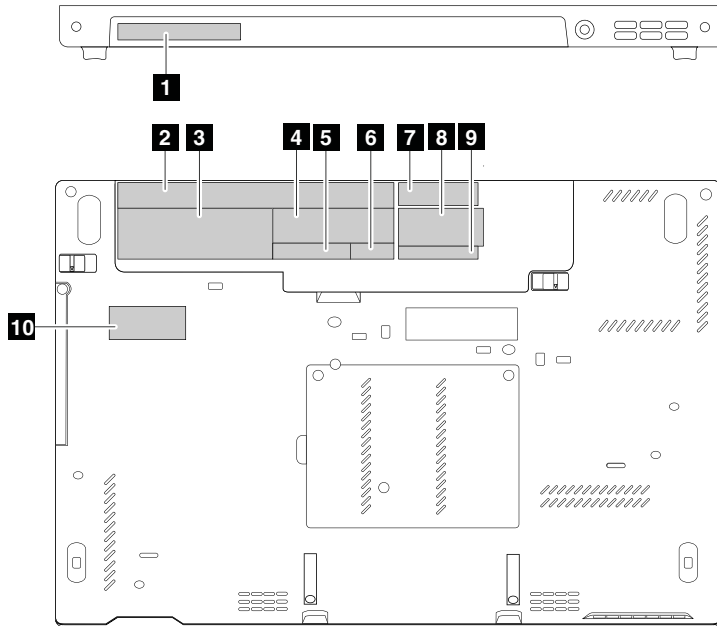

1 Information label	6 SIM icon label
2 System label	7 Taiwan GEO label
3 Certificate of Authentication (COA) label	8 Wireless WAN label
4 Serial number label	9 Taiwan wireless WAN label
5 FCC label	10 China GEO label

1140 Systemboard, DC-in connector, thermal fan assembly, and ExpressCard slot

Important notices for handling the system board:

When handling the system board, bear the following in mind:

- The system board has an accelerometer, which can be broken if several thousands of G-forces are applied.

Note: Dropping a system board from a height of as little as 6 inches so that it falls flat on a hard bench can subject the accelerometer to as much as 6,000 G's of shock.

- Be careful not to drop the system board on a bench top that has a hard surface, such as metal, wood, or composite.
- If a system board is dropped, be sure to document the drop in any reject report, and replace the system board.
- Avoid rough handling of any kind.
- At every point in the process, be sure not to drop or stack the system board.
- If you put a system board down, be sure to put it only on a padded surface such as an ESD mat or a corrugated conductive surface.

For access, remove these FRUs in order:

- “1010 Battery pack” on page 56
- “1020 Hard disk drive or solid-state drive” on page 57

- “1030 Memory module” on page 59
- “1040 Keyboard” on page 60
- “1050 Palm rest” on page 63
- “1060 Backup battery” on page 65
- “1080 PCI Express Mini Card for wireless LAN/WiMAX” on page 68
- “1090 PCI Express Mini Card for wireless WAN or mSATA solid-state drive” on page 70
- “1100 Bluetooth daughter card ” on page 74
- “1110 Keyboard bezel” on page 75
- “1120 LCD unit” on page 77
- “1130 Base cover assembly ” on page 80

Attention: The following components soldered on the system board are extremely sensitive. When you service the system board, avoid any kind of rough handling.

- a** Platform Controller Hub (PCH)
- b** Microprocessor
- c** Accelerometer chip for the hard disk drive Active Protection System™

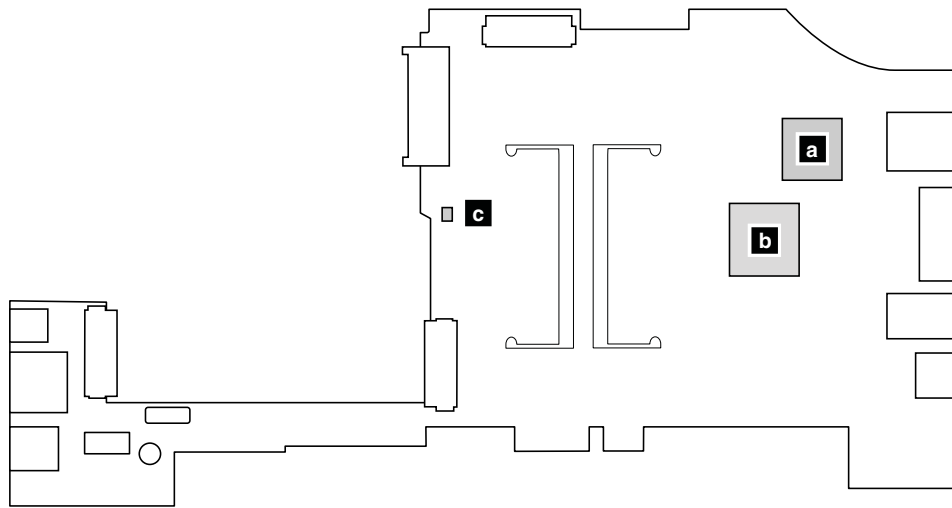

Removal steps of system board, DC-in connector, thermal fan assembly, and ExpressCard slot

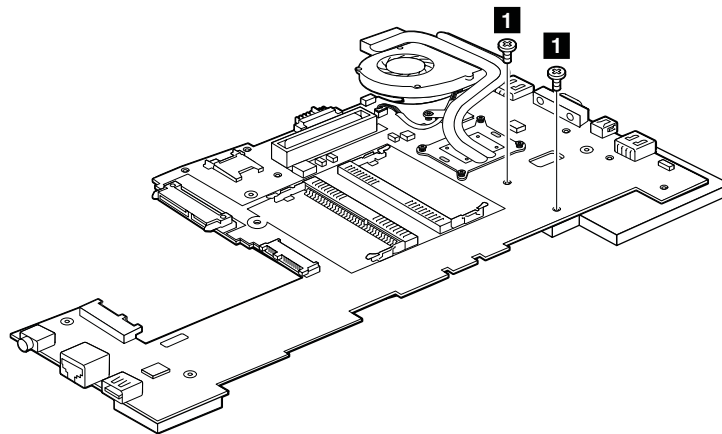

Step	Screw (quantity)	Color	Torque
1	M2 × 3.5 mm, flat-head, nylon-coated (2)	Silver	0.181 Nm (1.85 kgf-cm)

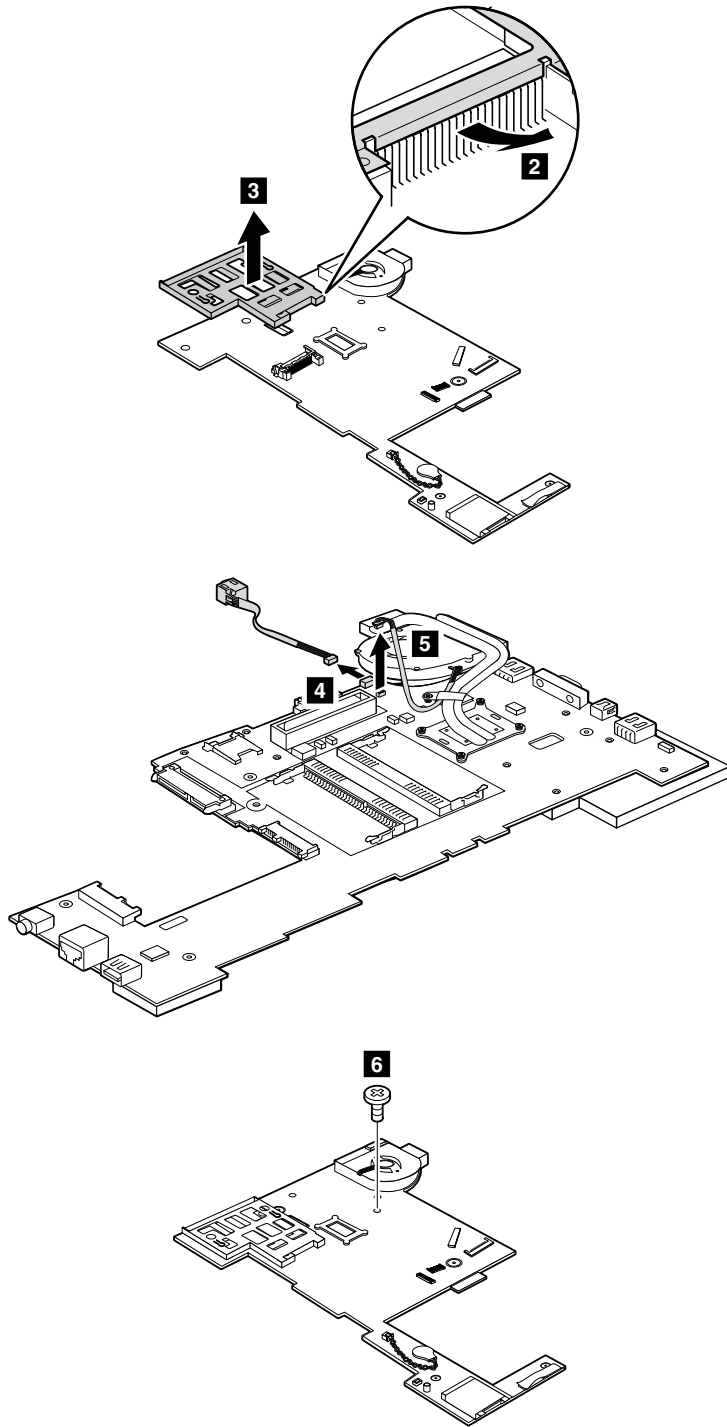

Step	Screw (quantity)	Color	Torque
6	M2 × 3.5 mm, wafer-head, nylon-coated (1)	Silver	0.181 Nm (1.85 kgf-cm)

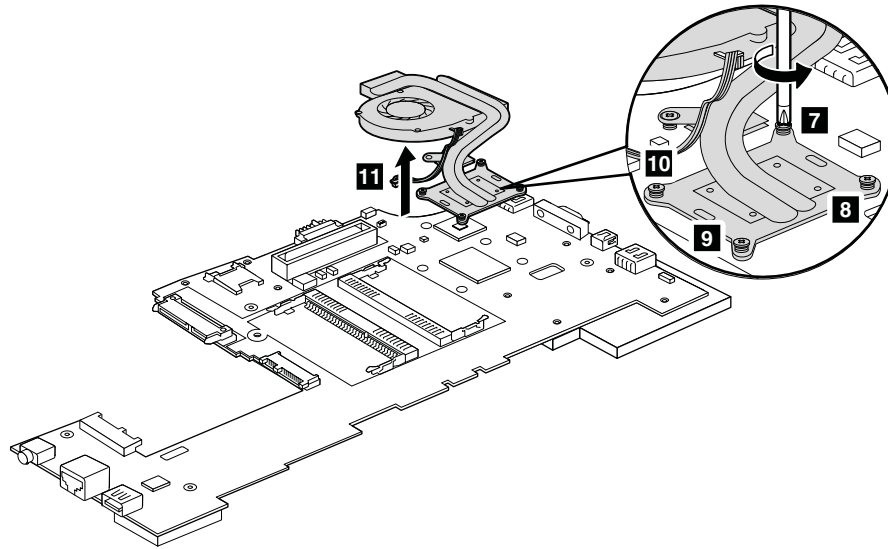

When installing:

- Ensure that the DC-in connector and the fan connector are attached to the system board firmly.
- Do not press the top of the fan cover and the fan hub
- Before you attach the fan assembly to the computer, apply thermal grease, at an amount of 0.2 grams, on the part marked **a** as in the following illustration. Either too much or too less application of grease can cause a thermal fan problem due to imperfect contact with a component. You need to peel the thin film off from the rubber **b**.

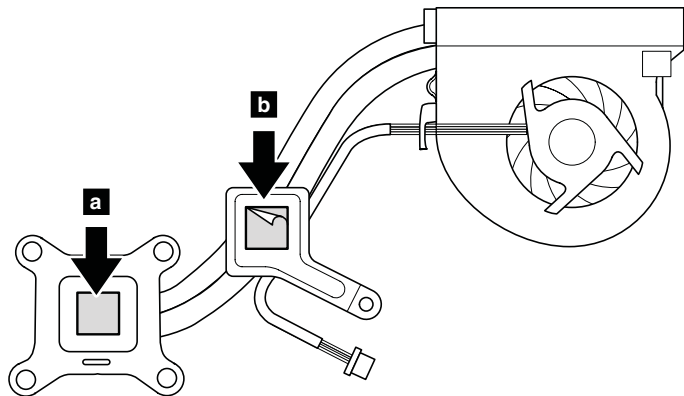



2010 LCD front bezel

For access, remove this FRU:

- “1010 Battery pack” on page 56

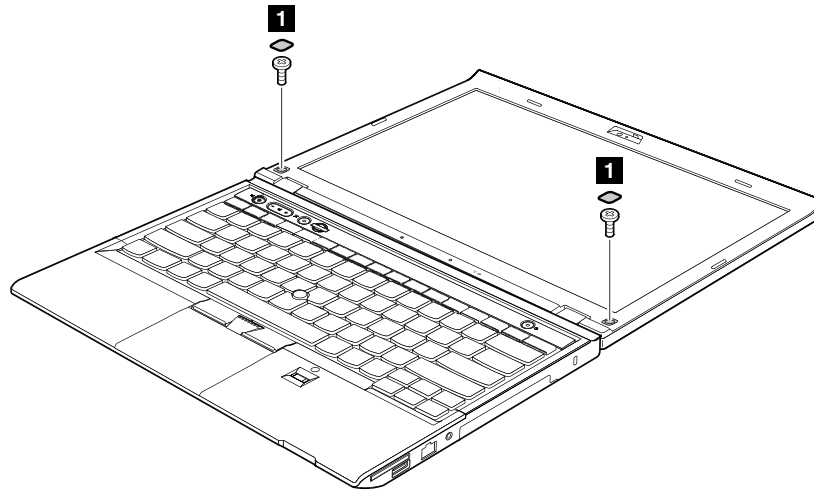
Removal steps of LCD front bezel



Step	Screw cap	Screw (quantity)	Color	Torque
1		M2.5 × 4 mm, wafer-head, nylon-coated (2)	Silver	0.392 Nm (4 kgf-cm)

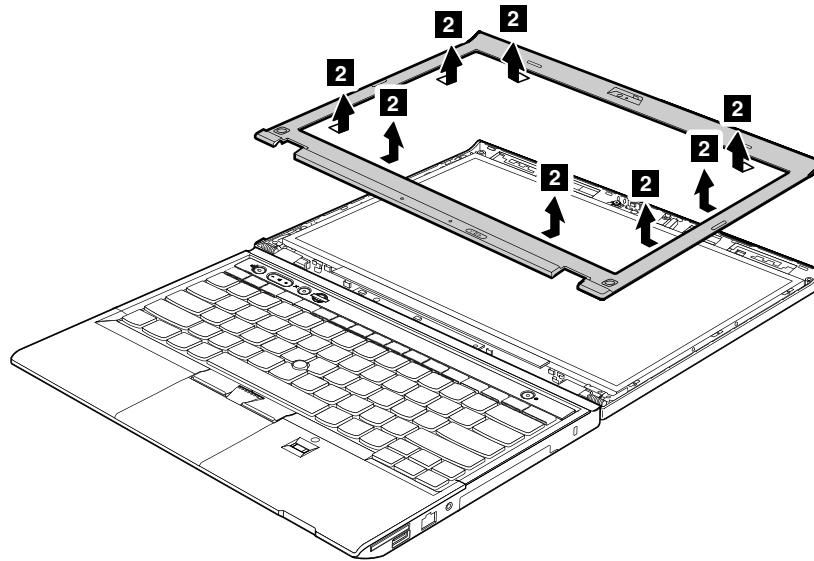

When installing: Ensure that all the claws are attached firmly.

2020 Integrated camera

For access, remove these FRUs in order:

- “1010 Battery pack” on page 56
- “2010 LCD front bezel” on page 85

Removal steps of Integrated camera

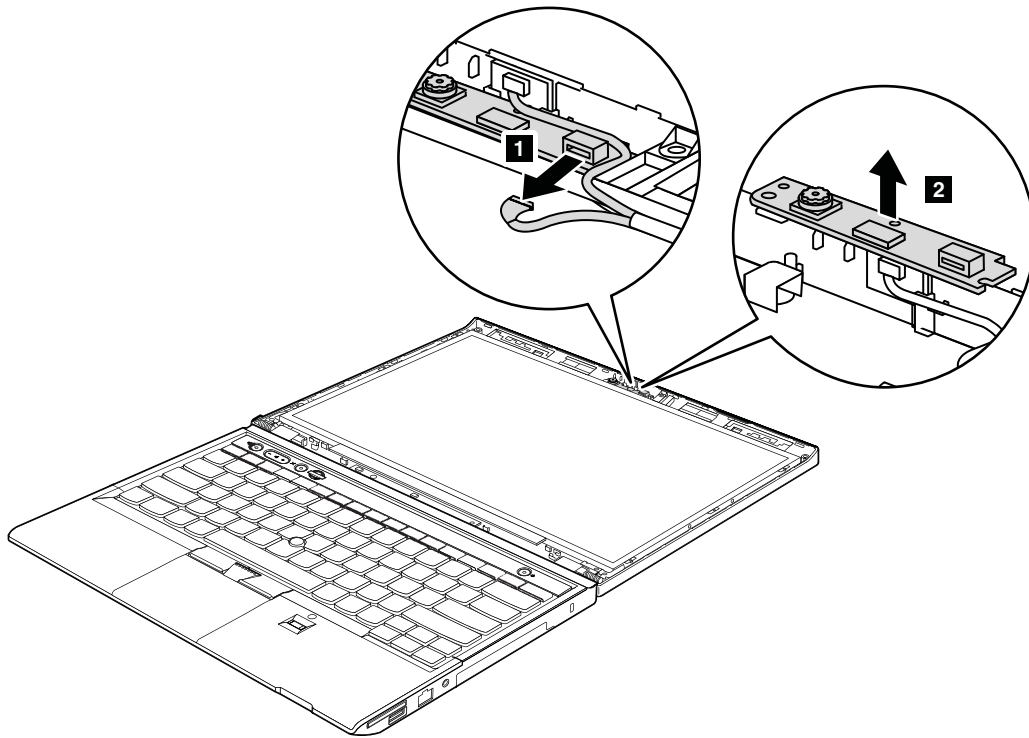

When installing: Ensure that the connector is attached firmly.

2030 LCD panel

For access, remove these FRUs in order:

- “1010 Battery pack” on page 56
- “2010 LCD front bezel” on page 85

Removal steps of LCD panel

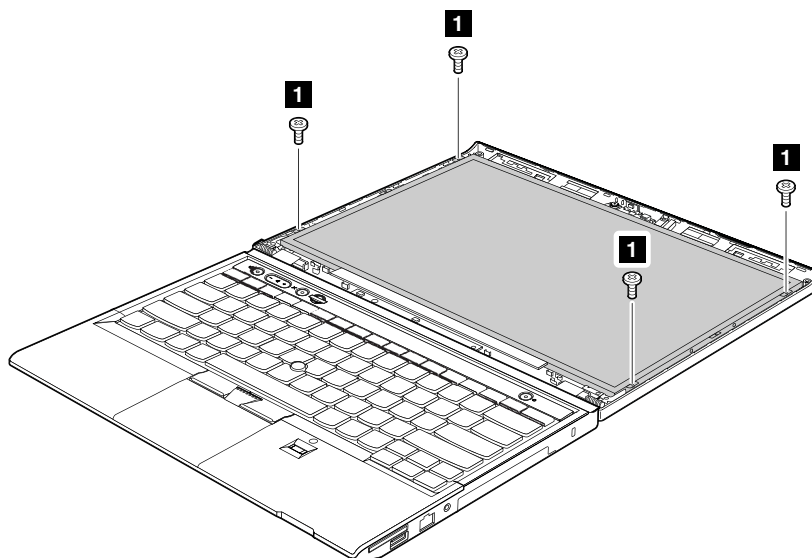

Step	Screw (quantity)	Color	Torque
1	M2 × 3.5 mm, wafer-head, nylon-coated (4)	Silver	0.181 Nm (1.85 kgf-cm)

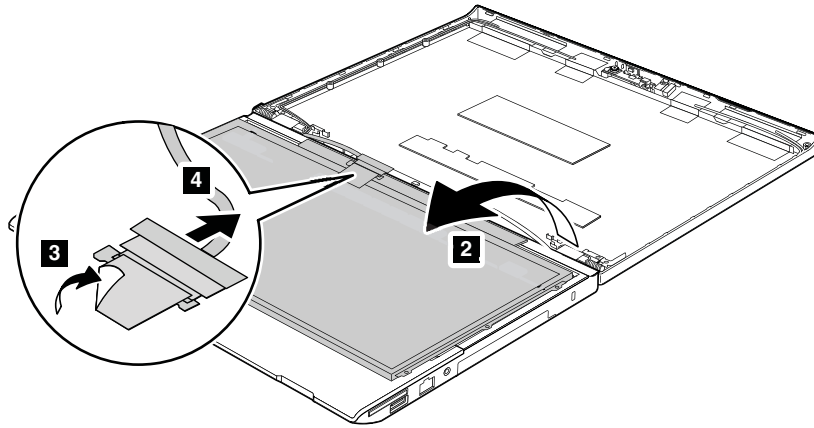

When installing: When attaching the LCD panel to the cover, press the left and right edges covered with metal gently with your fingers. Do not press the surface of the panel or apply any excessive force to the panel. Ensure that the LCD cable connector is attached firmly.

2040 LED board

For access, remove these FRUs in order:

- “1010 Battery pack” on page 56
- “2010 LCD front bezel” on page 85
- “2060 LCD cable” on page 90

Removal steps of LED board

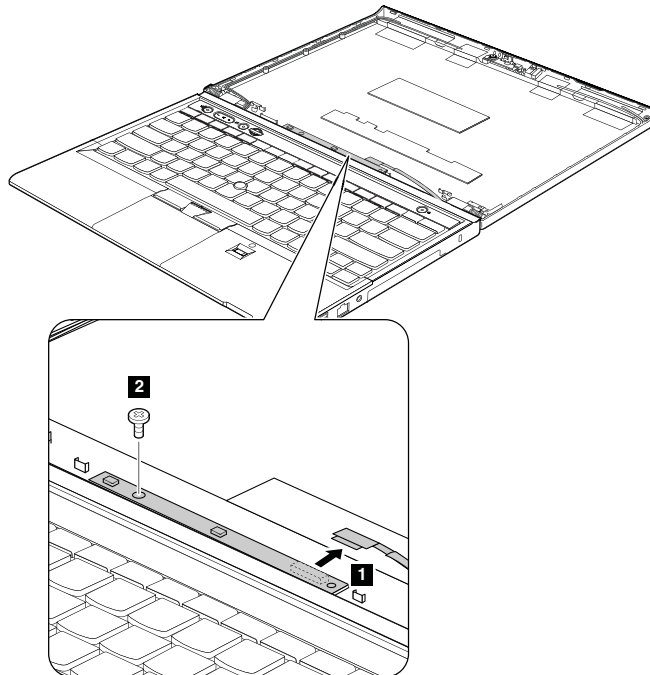

Step	Screw (quantity)	Color	Torque
2	M2 × 3.5 mm, wafer-head, nylon-coated (1)	Silver	0.181 Nm (1.85 kgf-cm)

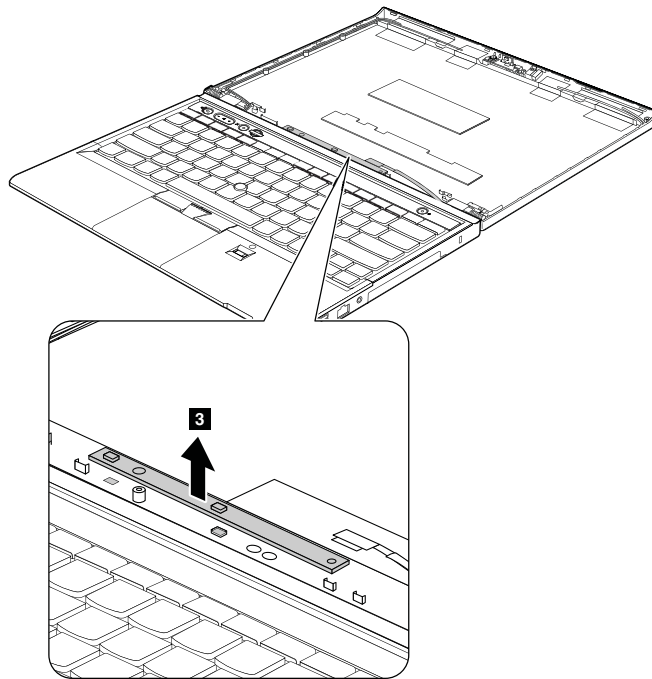

When installing: Ensure that connector is attached firmly. Route the connector cable as in the following illustration.

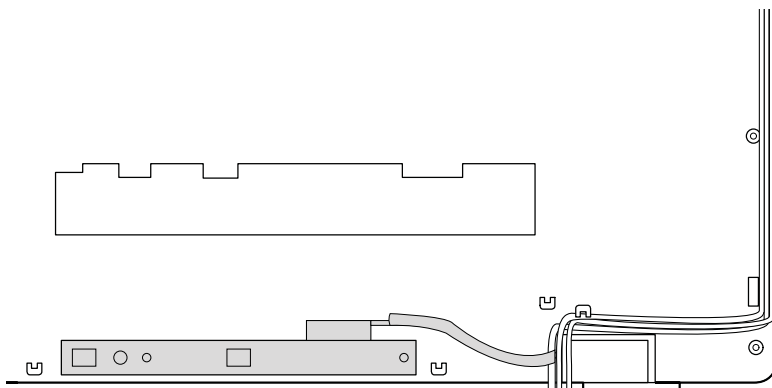

2050 Hinges

For access, remove these FRUs in order:

- “1010 Battery pack” on page 56
- “1040 Keyboard” on page 60
- “1050 Palm rest” on page 63

- “1110 Keyboard bezel” on page 75
- “1120 LCD unit” on page 77
- “2010 LCD front bezel” on page 85

Removal steps of hinges

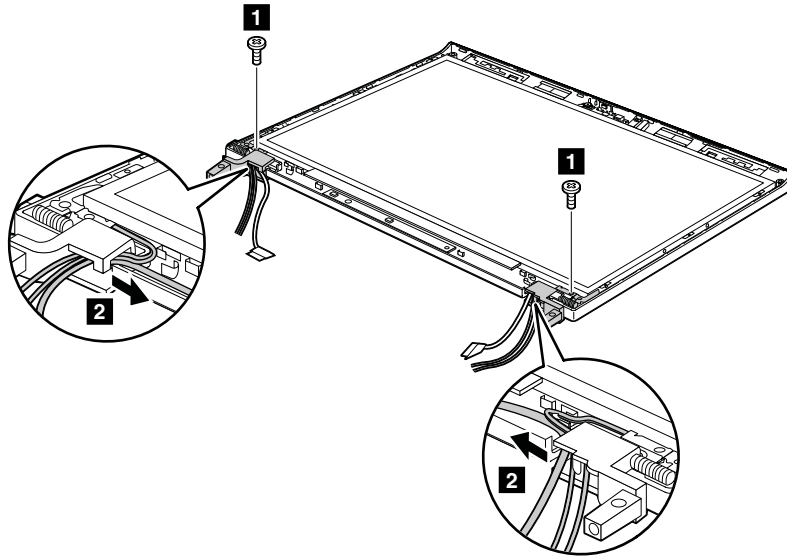

Step	Screw (quantity)	Color	Torque
1	M2 x 3.5 mm, wafer-head, nylon-coated (2)	Silver	0.392 Nm (4 kgf-cm)

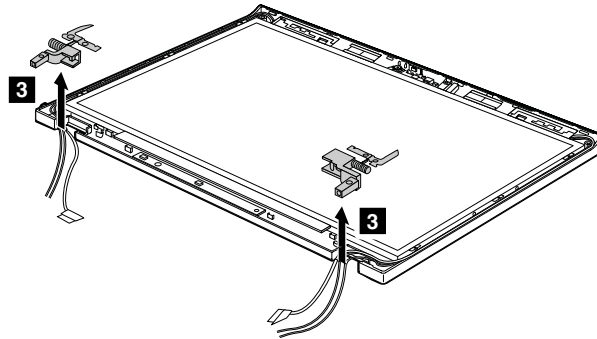

2060 LCD cable

For access, remove these FRUs in order:

- “1010 Battery pack” on page 56
- “1040 Keyboard” on page 60
- “1050 Palm rest” on page 63
- “1110 Keyboard bezel” on page 75
- “1120 LCD unit” on page 77
- “2010 LCD front bezel” on page 85
- “2030 LCD panel” on page 87

Removal steps of LCD cable

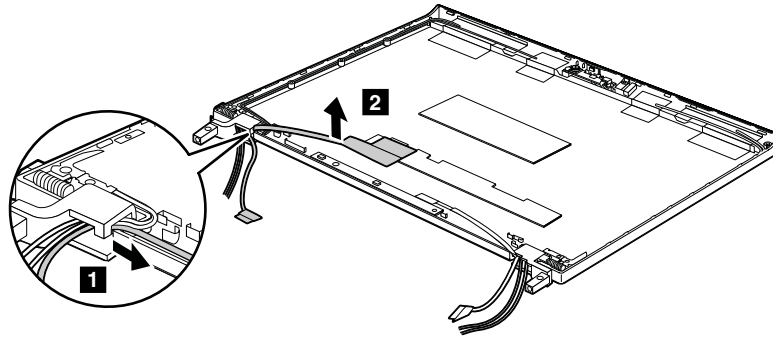

When installing: Ensure that the LCD cable connector is attached firmly.

2070 LCD rear cover assembly, LED and camera cable, and wireless antenna set

For access, remove these FRUs in order:

- “1010 Battery pack” on page 56
- “1040 Keyboard” on page 60
- “1050 Palm rest” on page 63
- “1110 Keyboard bezel” on page 75
- “1120 LCD unit” on page 77
- “2010 LCD front bezel” on page 85
- “2020 Integrated camera” on page 86
- “2040 LED board” on page 88
- “2030 LCD panel” on page 87
- “2050 Hinges” on page 89
- “2060 LCD cable” on page 90

Removal steps of LED and camera cable

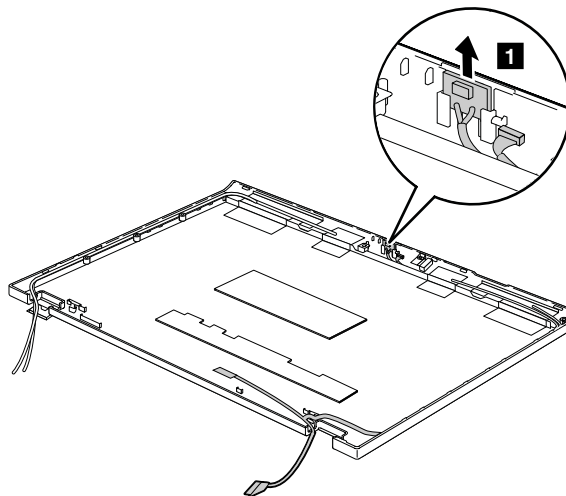

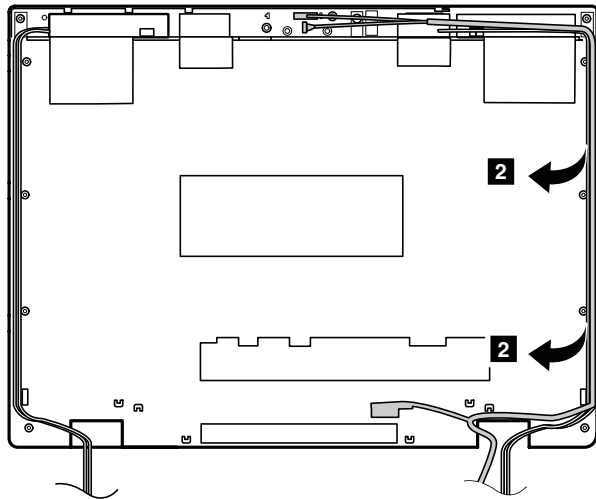

Removal steps of wireless antenna set

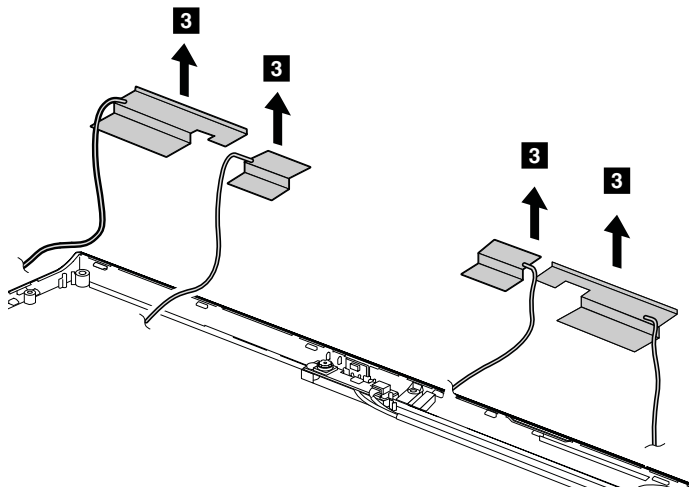
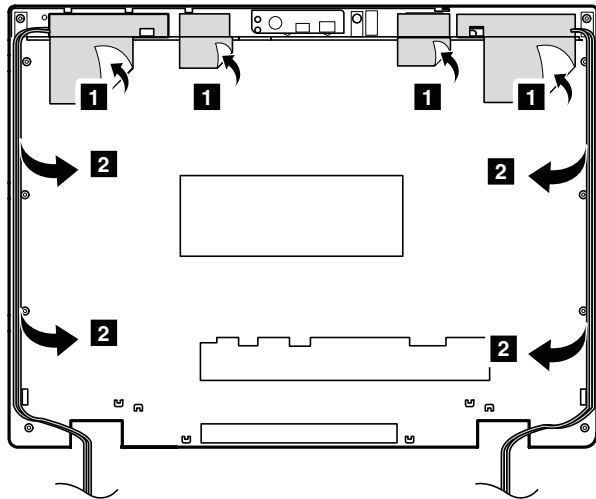

When installing: When you install the wireless antenna set, route the cables as shown in the following illustration. As you route the cables, ensure that they are not subject to any tension. Tension could cause the cables to be damaged by the cable guides, or a wire to be broken.

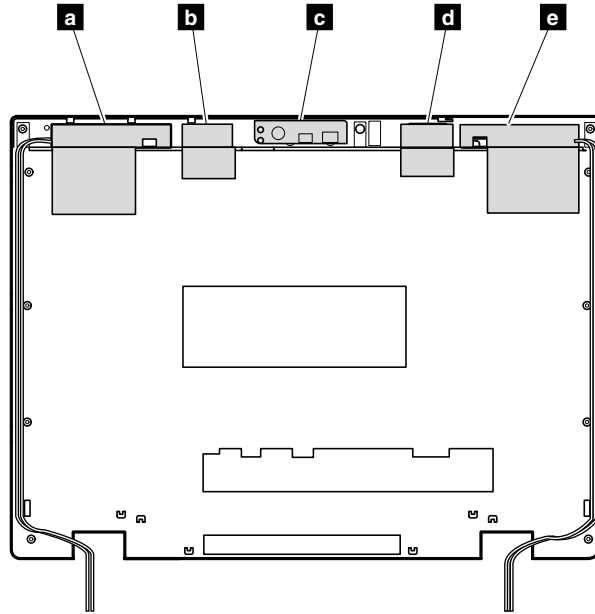

- a** Wireless WAN antenna, AUX (blue)
- b** Wireless LAN antenna, AUX (black)
- c** Wireless LAN antenna, 3rd (white)
- d** Wireless LAN antenna, MAIN (gray)
- e** Wireless WAN antenna, MAIN (red)

Appendix A. Notices

Lenovo may not offer the products, services, or features discussed in this document in all countries. Consult your local Lenovo representative for information on the products and services currently available in your area. Any reference to a Lenovo product, program, or service is not intended to state or imply that only that Lenovo product, program, or service may be used. Any functionally equivalent product, program, or service that does not infringe any Lenovo intellectual property right may be used instead. However, it is the user's responsibility to evaluate and verify the operation of any other product, program, or service.

Lenovo may have patents or pending patent applications covering subject matter described in this document. The furnishing of this document does not give you any license to these patents. You can send license inquiries, in writing, to:

*Lenovo (United States), Inc.
1009 Think Place - Building One
Morrisville, NC 27560
U.S.A.
Attention: Lenovo Director of Licensing*

LENOVO PROVIDES THIS PUBLICATION "AS IS" WITHOUT WARRANTY OF ANY KIND, EITHER EXPRESS OR IMPLIED, INCLUDING, BUT NOT LIMITED TO, THE IMPLIED WARRANTIES OF NON-INFRINGEMENT, MERCHANTABILITY OR FITNESS FOR A PARTICULAR PURPOSE. Some jurisdictions do not allow disclaimer of express or implied warranties in certain transactions, therefore, this statement may not apply to you.

This information could include technical inaccuracies or typographical errors. Changes are periodically made to the information herein; these changes will be incorporated in new editions of the publication. Lenovo may make improvements and/or changes in the product(s) and/or the program(s) described in this publication at any time without notice.

The products described in this document are not intended for use in implantation or other life support applications where malfunction may result in injury or death to persons. The information contained in this document does not affect or change Lenovo product specifications or warranties. Nothing in this document shall operate as an express or implied license or indemnity under the intellectual property rights of Lenovo or third parties. All information contained in this document was obtained in specific environments and is presented as an illustration. The result obtained in other operating environments may vary.

Lenovo may use or distribute any of the information you supply in any way it believes appropriate without incurring any obligation to you.

Any references in this publication to non-Lenovo Web sites are provided for convenience only and do not in any manner serve as an endorsement of those Web sites. The materials at those Web sites are not part of the materials for this Lenovo product, and use of those Web sites is at your own risk.

Any performance data contained herein was determined in a controlled environment. Therefore, the result obtained in other operating environments may vary significantly. Some measurements may have been made on development-level systems and there is no guarantee that these measurements will be the same on generally available systems. Furthermore, some measurements may have been estimated through extrapolation. Actual results may vary. Users of this document should verify the applicable data for their specific environment.

Electronic emission notices

For electronic emission information on Class B digital devices, refer to the corresponding information in the *User Guide*.



Trademarks

The following terms are trademarks of Lenovo in the United States, other countries or both:

- Active Protection System
- Lenovo
- ThinkLight
- ThinkPad
- ThinkVantage
- TrackPoint
- Ultrabay
- UltraNav

Microsoft Windows and Windows Server are trademarks of Microsoft group of companies.

Intel is a trademark of Intel Corporation in the U.S. and/or other countries.

Other company, product, or service names may be the trademarks or service marks of others.

ThinkPad®

Part Number: 0B48666_01

Printed in China

(1P) P/N: 0B48666_01

